

US MARKET

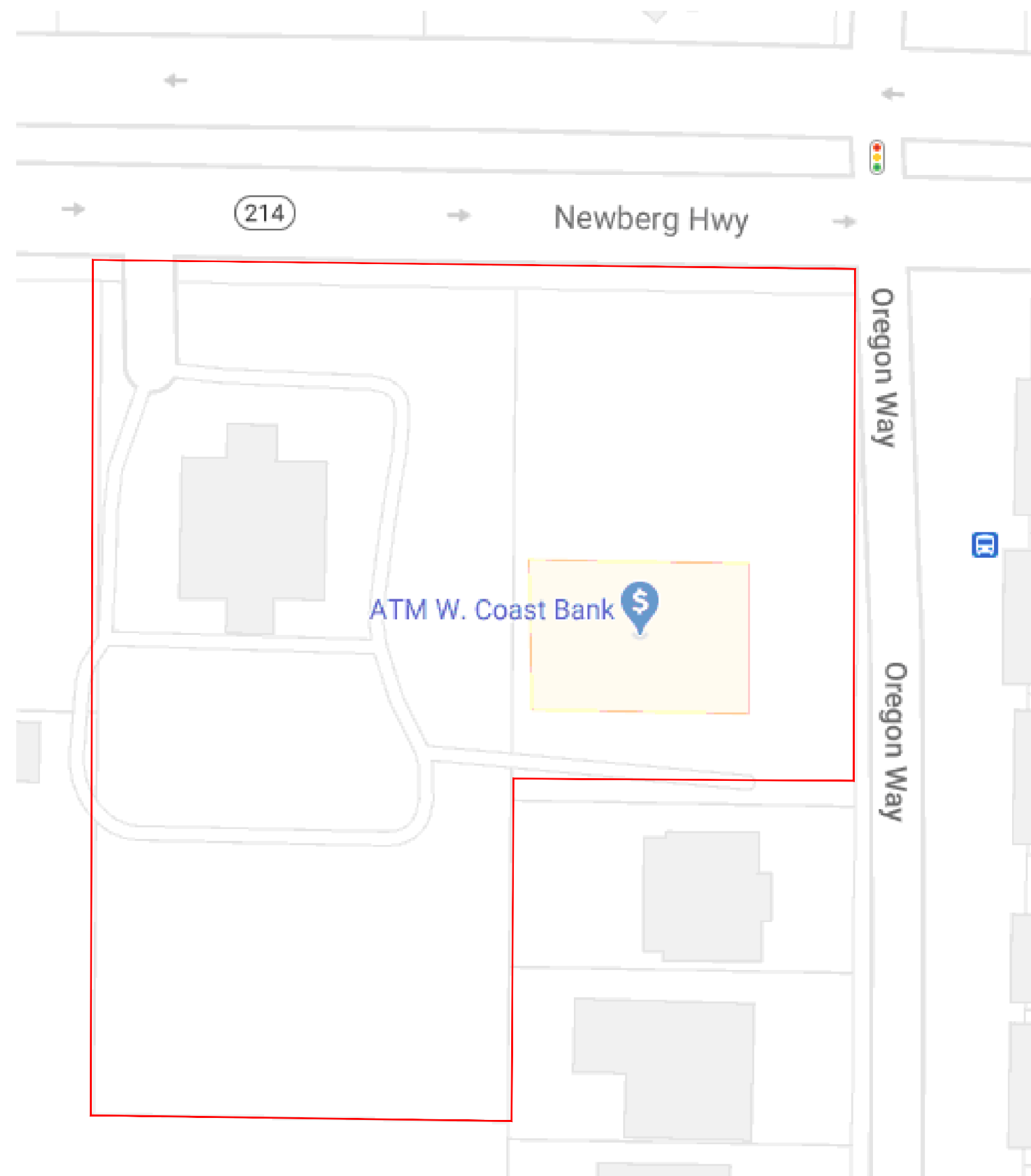

VICINITY MAP
SCALE: NTS

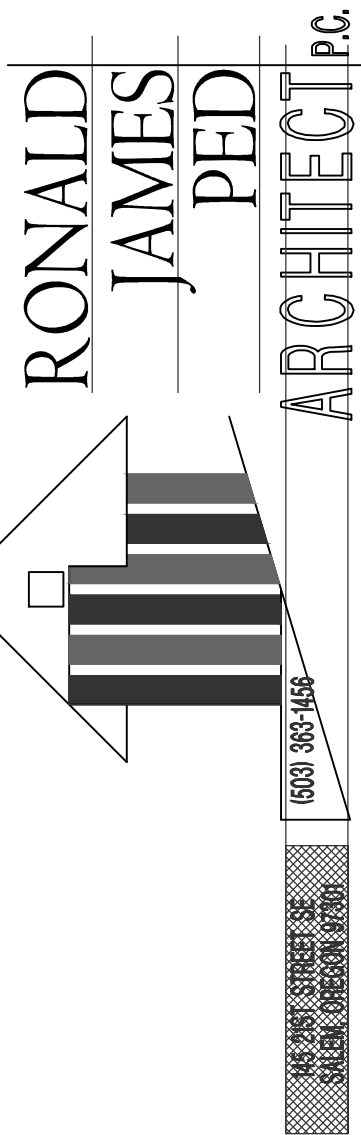
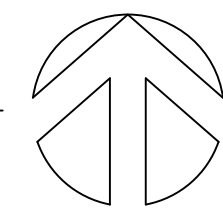

CODE SUMMARY

CODE: 2019 069C
OCCUPANCY: M
CONSTRUCTION: V-B

ALLOWABLE BUILDING AREAS-TABLE 503

OCCUPANCY	CONSTRUCTION TYPE	TABULAR BUILDING AREA	ACTUAL AREA
M	V-B	9,000 SF	9,973 SF

SITE PLAN SUMMARY

ZONED: CG - GENERAL COMMERCIAL

PROPERTY SIZE = 62,120.42 S.F. (1.43 AC)
REQ'D LANDSCAPE P.U. = 484 P.U.
PROPOSED LANDSCAPE P.U. = 741 P.U.

PARKING REQ.

TOTAL PARKING:
GEN. RETAIL: 4110 SQ.FT. / 250 = 16.4, 17 REQ. (item 7 table 3.05A)
OFFICE: 6,863 SQ.FT. / 350 = 19.6, 20 REQ. (item 12 table 3.05A)
TOTAL REQUIRED SPACES: 37 REQ.
PARKING SPACES: 53 PROVIDED (3 van accessible spaces)
(30 full size spaces & 23 compact spaces)*
* 37 req. spaces x .2 = 7.4, 7 compact spaces max,
plus 16 additional compact spaces beyond req. number of spaces

STREET TREES REQ.

ONE TREE EVERY 50'-0" REQ.
8 TREES PROPOSED

BIKE PARKING REQ.

3.05.03 Off-Street Parking
E. All uses that are required to provide 10 or more off-street parking spaces and residential structures with four or more dwelling or living units shall provide a bicycle rack within 50 feet of the main building entrance. The number of required rack spaces shall be one space per ten vehicle parking spaces, with a maximum of 20 rack spaces.

54/10 = 6 REQUIRED
2 BIKE RACKS (4 BIKE SPACES) PROVIDED AT CONVENIENCE STORE
1 BIKE RACK (2 BIKE SPACES) PROVIDED AT OFFICE BUILDING
(2 BIKE PER RACK)

DRAWING INDEX

- A1.0 COVER PAGE
- A1.1 SITE PLAN
- A1.1a PHASING PLAN
- A1.2 EXISTING SITE & DEMO PLAN
- A1.3 FIRE ACCESS PLAN
- C1.1 GRADING PLAN
- C1.2 UTILITY PLAN
- E1.1 LIGHTING PLAN
- L1.1 LANDSCAPE PLAN
- A3.1 BLDG ELEVATIONS & RENDERINGS



LAST SAVED: Tue, 06 Feb 2024 - 10:57 am LOCATION: C:\Users\kevin\AppData\Local\Temp\AcPublish_2428\A1.1 Updated Site 2.1.24.dwg A1.0
PRINTED: Tue, 06 Feb 2024 - 11:40 am PRINTED BY: kevin

NEW OFFICE, RETAIL AND GAS STATION
US MARKET
2600 NEWBERG HIGHWAY WOODBURN OREGON

DATE: DEC. 1, 2020
DRAWN: GLM / KDG
JOB NO. 1984

A1.0

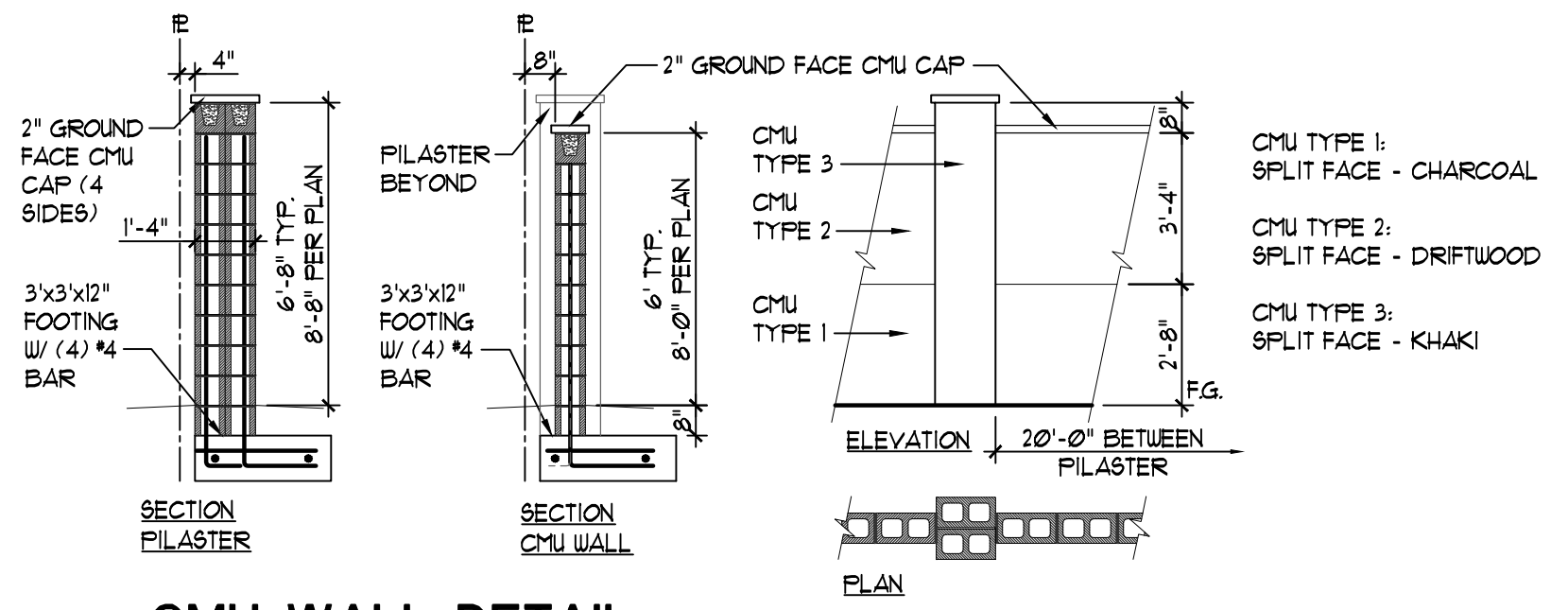

1 CMU WALL DETAIL
ARCHITECTURAL SCREEN WALL
 SCALE: 1/4" = 1'-0"

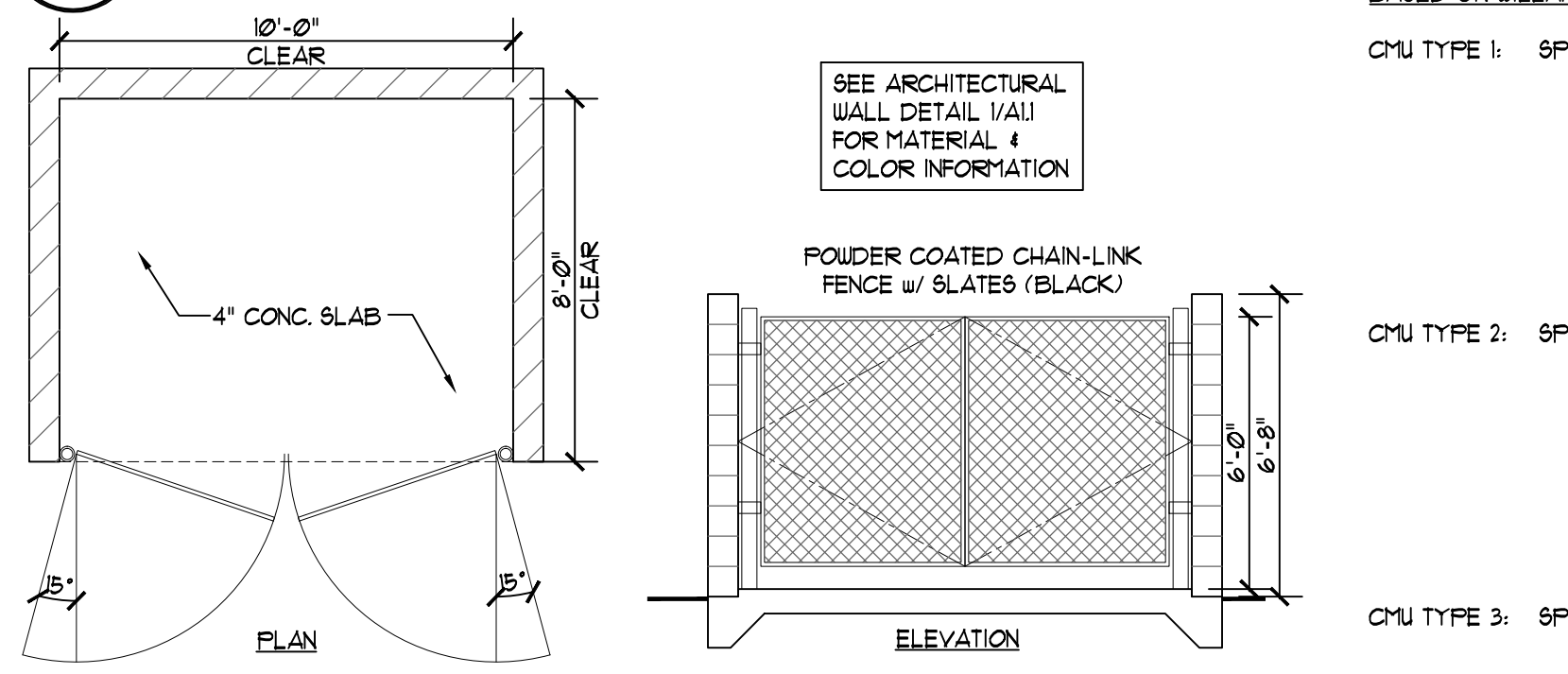

2 TRASH ENCLOSURE
 SCALE: 1/4" = 1'-0"

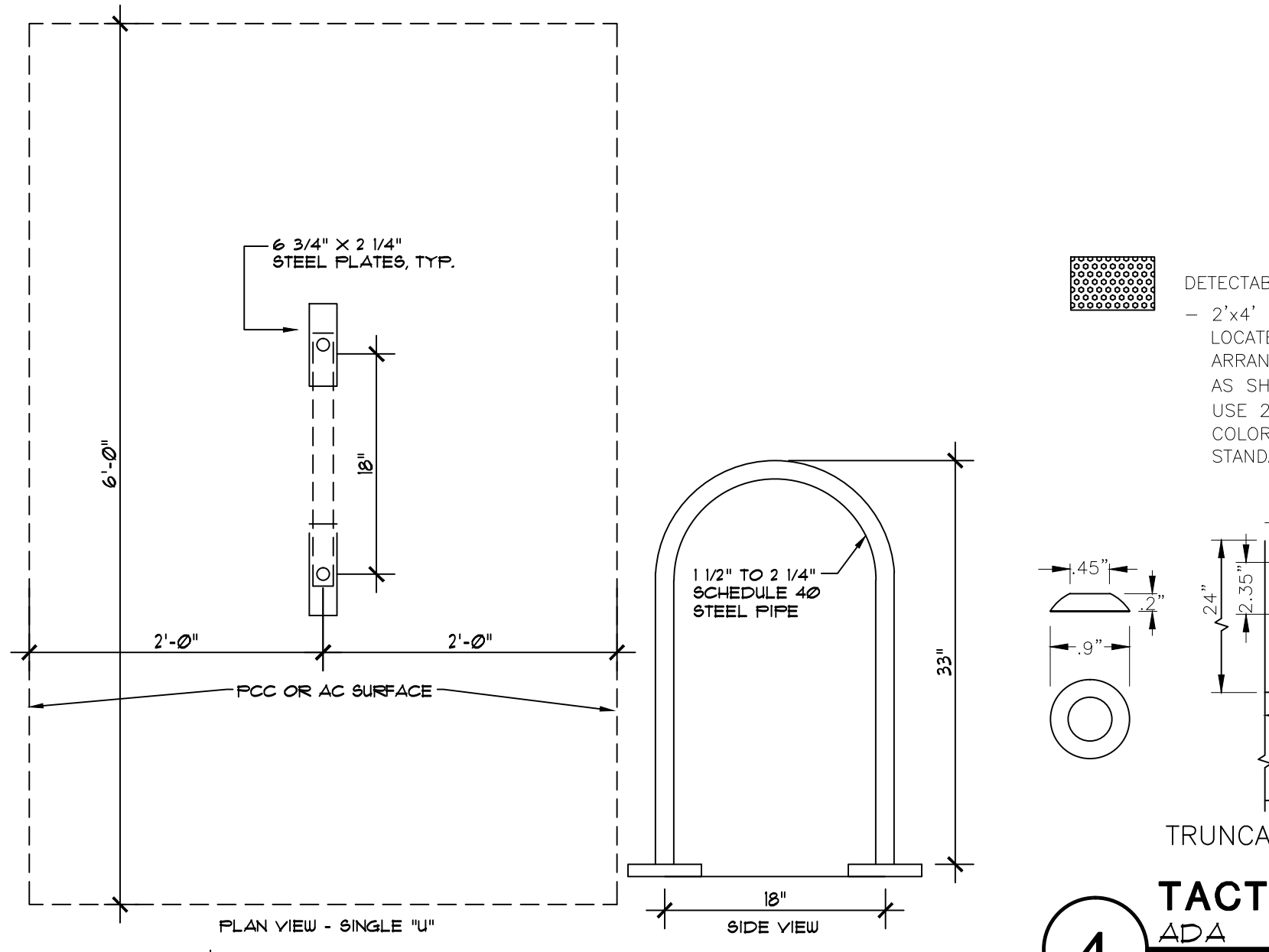

3 BICYCLE PARKING RACK DETAIL
 SCALE: 1" = 1'-0"

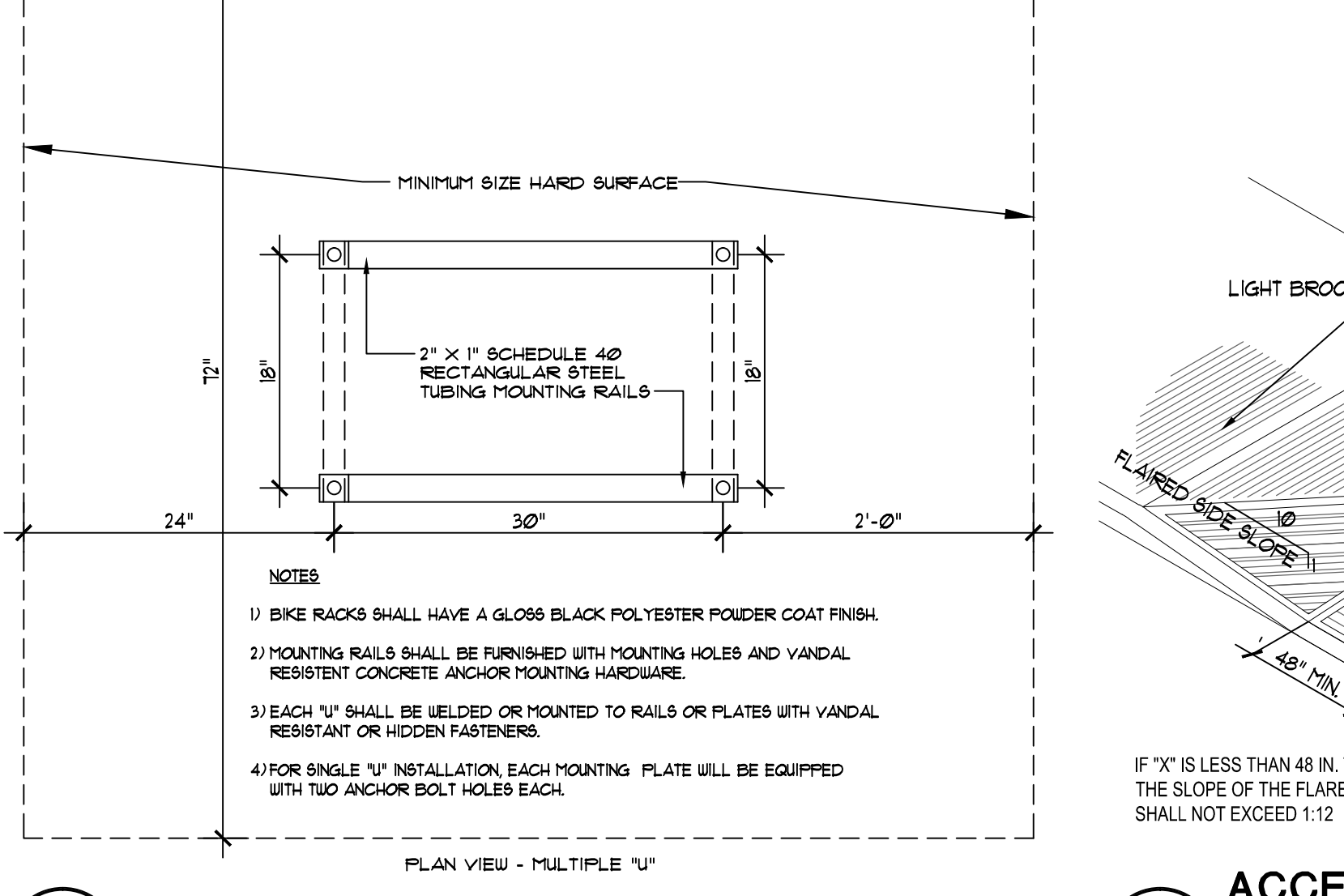

4 TACTILE WARNING
 SCALE: 1" = 1'-0"



5 ACCESSIBLE RAMP
 SCALE: 1/4" = 1'-0"

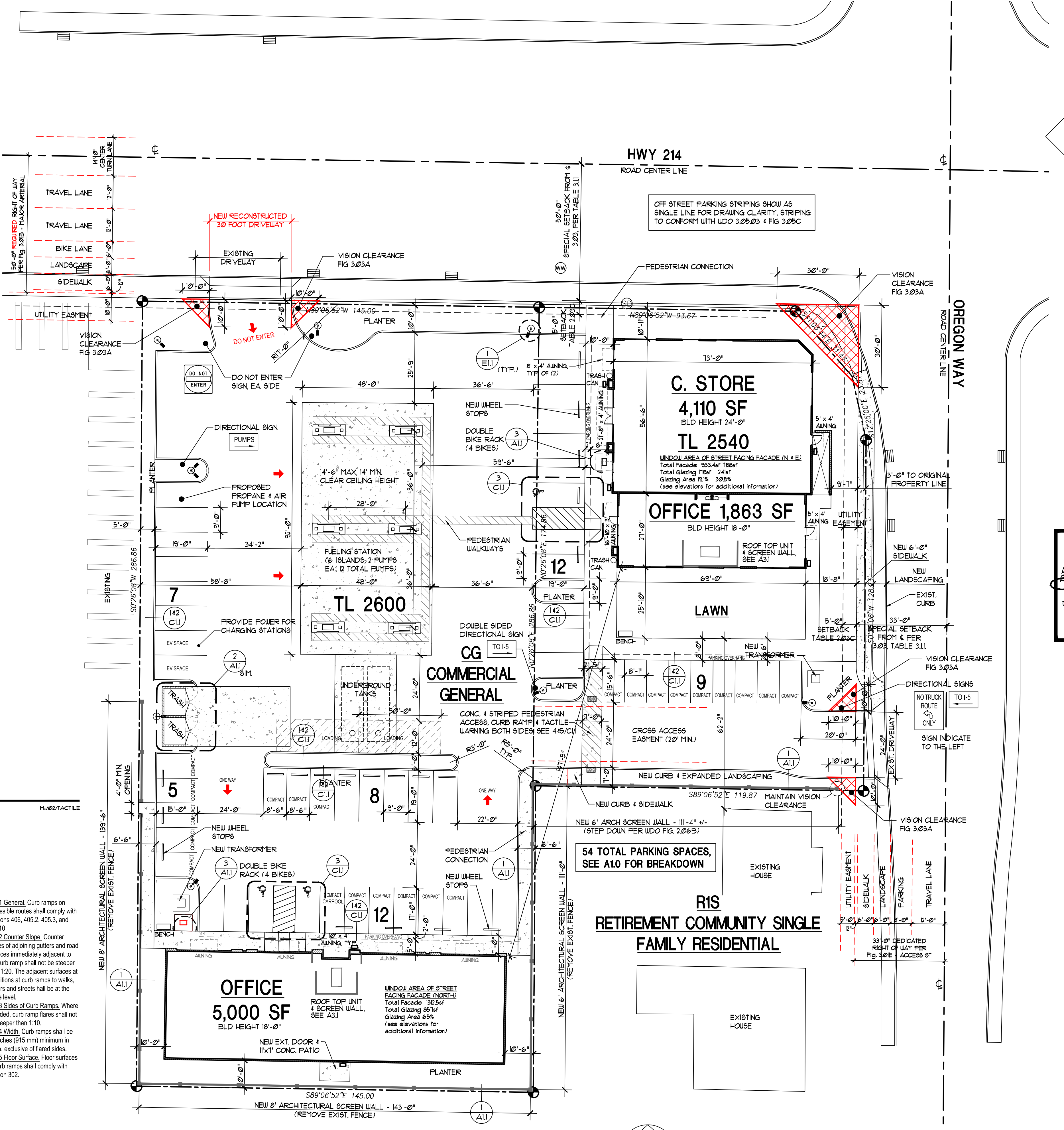

SITE PLAN
 SCALE: 1" = 20'

LOCATION: C:\Users\kevin\AppData\Local\Temp\AcPublish_2428\A1.1 Updated Site 2.1.24.dwg
 A1.1
 PRINTED BY: Kevin
 Tue, 06 Feb 2024 - 10:57 am
 Tue, 06 Feb 2024 - 11:40 am
 LAST SAVED: Tue, 06 Feb 2024 - 10:57 am
 PRINTED: Tue, 06 Feb 2024 - 11:40 am

PHASED CONSTRUCTION NOTES

1. ENSURE CONFORMANCE TO ALL WOODBURN DEVELOP ORDNANCE REQUIREMENTS
2. COORDINATE ALL PHASES OF THE PROJECT TO ENSURE APPROPRIATE MEASURES ARE TAKEN FOR FUTURE PHASE
3. COORDINATE ALL UTILITIES AND ACCOUNT FOR TIE-IN OF FUTURE PHASES
4. ENSURE ALL UTILITIES ARE APPROPRIATELY SIZED TO ACCOMMODATE FUTURE PHASES
5. COORDINATE SITE ACCESS & CIRCULATION SO EACH PHASE CAN ACT INDEPENDENT OF FUTURE PHASES

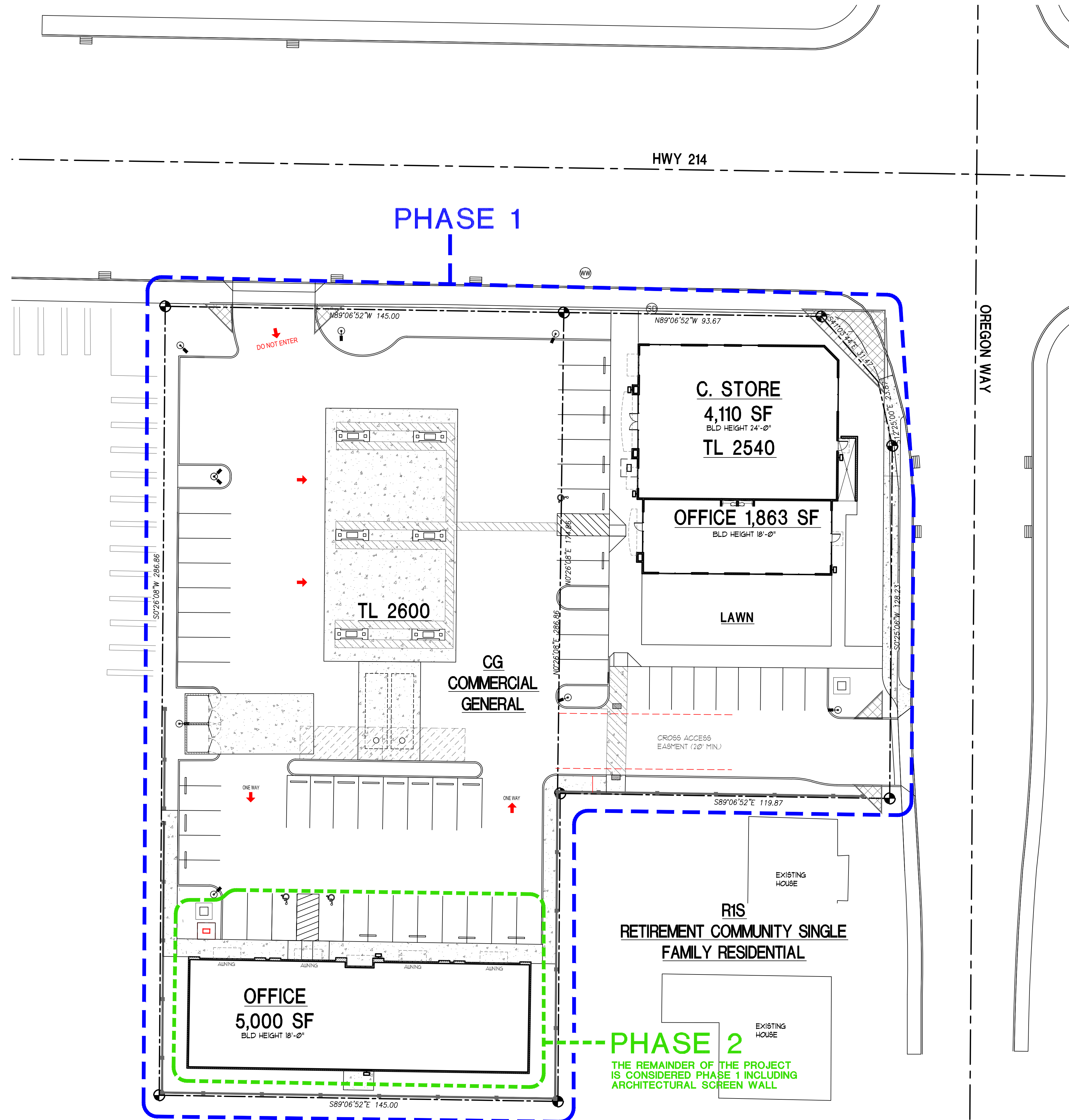

PHASING PLAN
SCALE: 1" = 20'

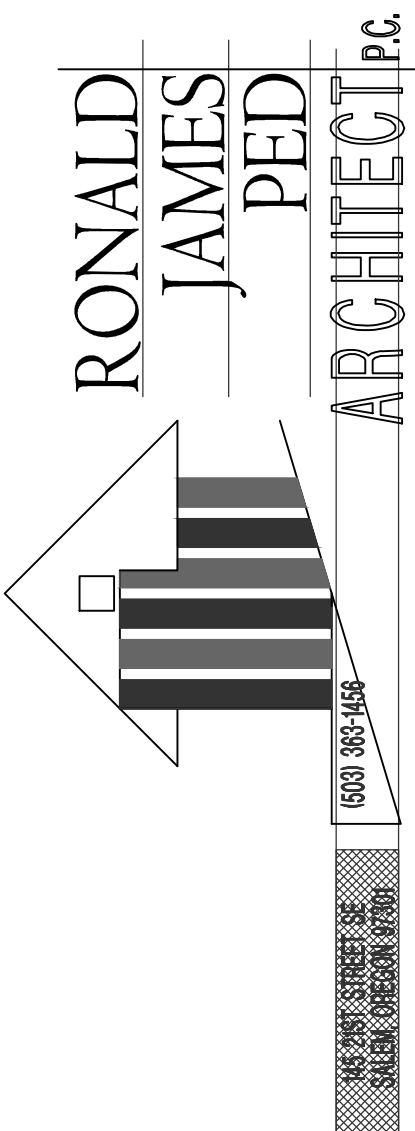

NEW OFFICE, RETAIL AND GAS STATION
US MARKET
2600 NEWBERG HIGHWAY WOODBURN OREGON

DATE: DEC. 1, 2020
DRAWN: AK / KDG
JOB NO.: 1984

A1.1a

LAST SAVED: Tue, 06 Feb 2024 - 10:57 am
LOCATION: C:\Users\kevin\AppData\Local\Temp\AcPublish_2428\A1.1 Updated Site 2.1.24.dwg A1.1a
PRINTED BY: Kevin

LAST SAVED: Tue, 06 Feb 2024 - 10:57 am LOCATION: C:\Users\kevin\AppData\Local\Temp\AcPublish_2428\A1.1 Updated Site 2.1.24.dwg A1.2
 PRINTED: Tue, 06 Feb 2024 - 11:40 am PRINTED BY: kevin

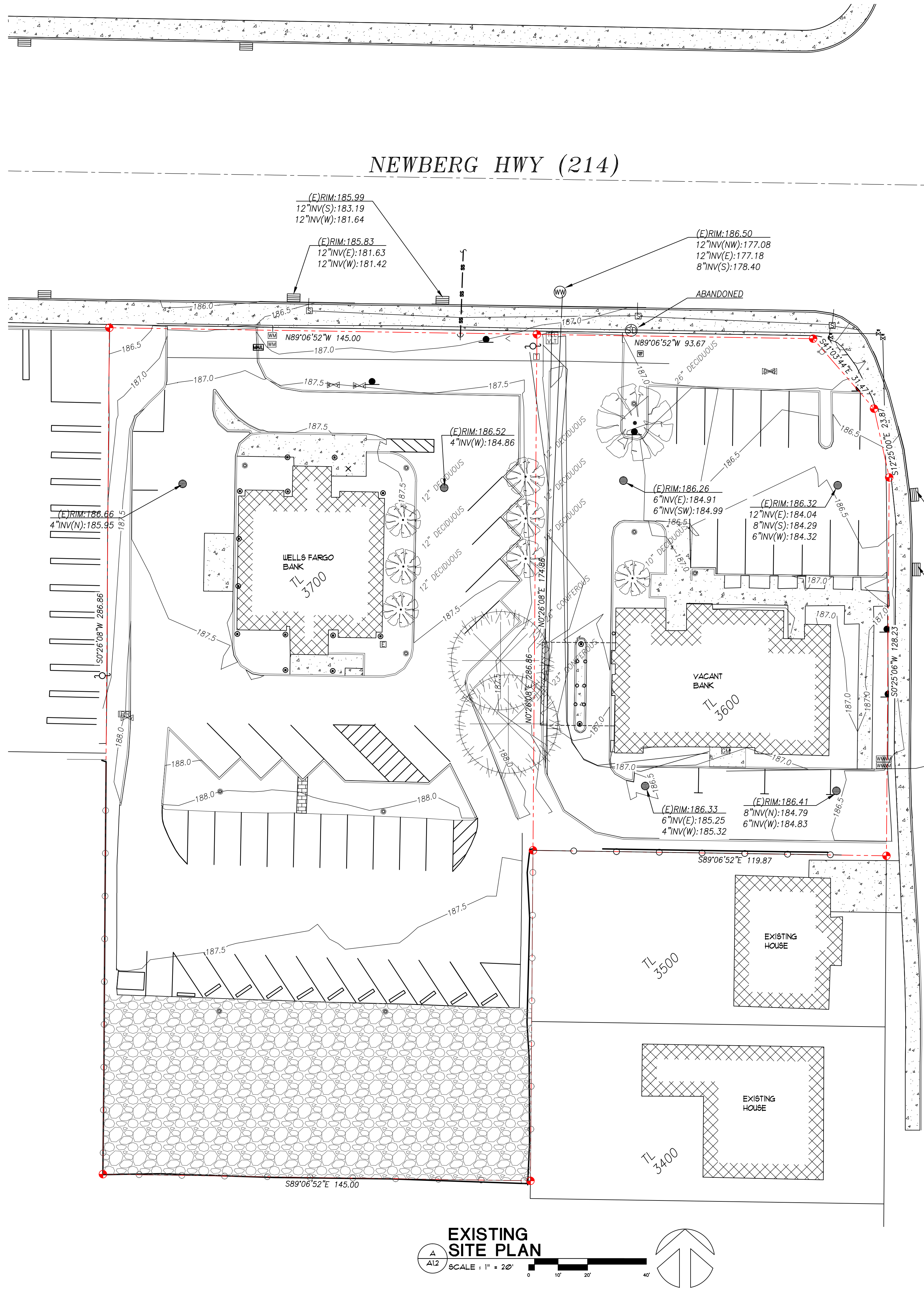
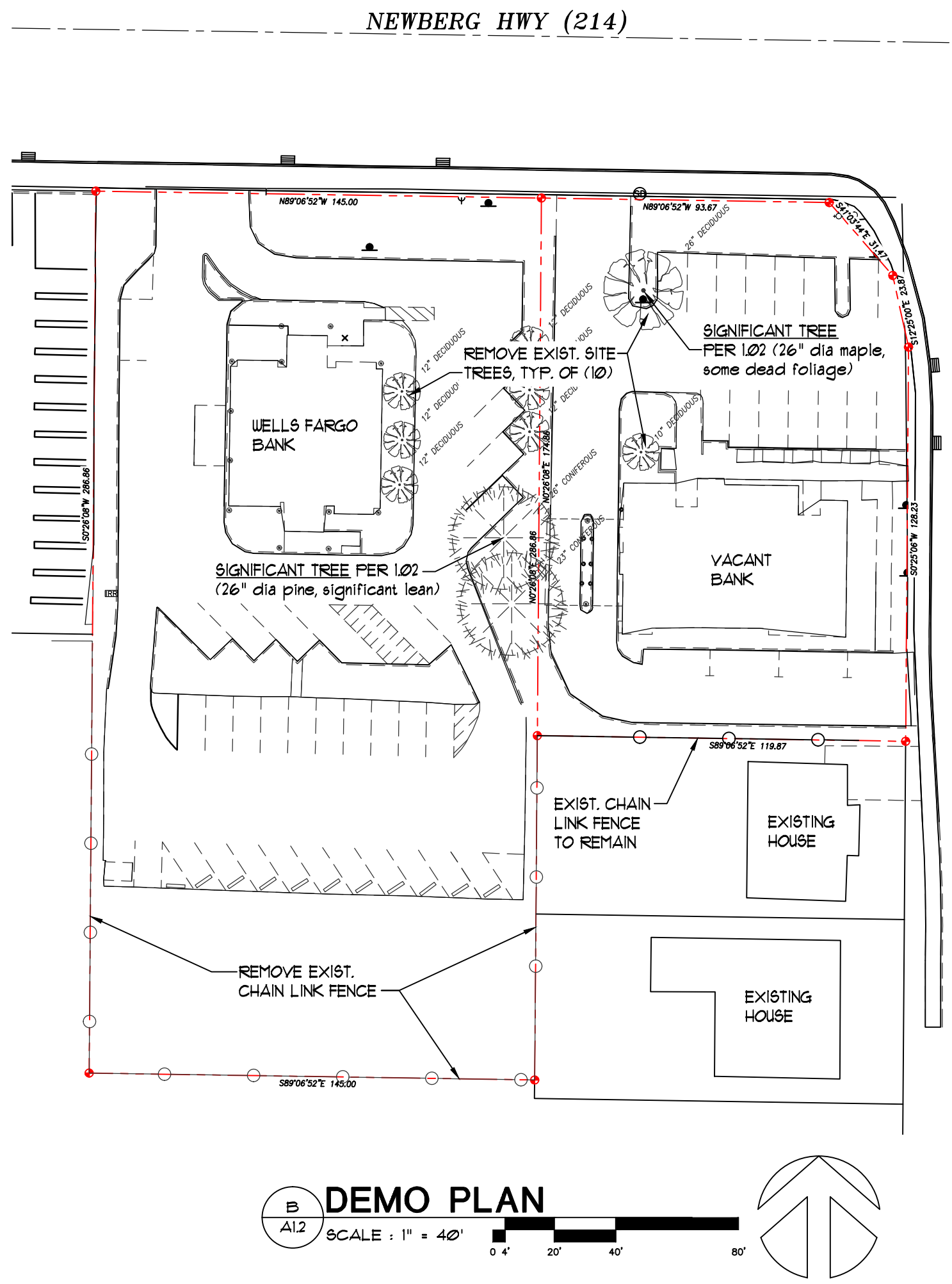

- LEGEND**
- PROPERTY LINE
 - ROW CENTER LINE
 - BUILDING WALL
 - BUILDING EAVE
 - CONTOUR LINE
 - EDGE OF ASPHALT
 - CURB
 - FENCE
 - E --- ELECTRIC LINE
 - G --- GAS LINE
 - S --- SIGNAL LINE
 - T --- TELEPHONE LINE
 - SS --- WASTE WATER LINE
 - W --- WATER LINE
 - AREA DRAIN
 - BOLLARD
 - Y CLEANOUT
 - COMMUNICATION RISER
 - ▣ CATCH BASIN
 - ⊙ DECIDUOUS TREE
 - ⊙ CONIFEROUS TREE
 - DOWNSPOUT
 - ⊠ ELECTRIC BOX
 - ⊠ ELECTRIC VAULT
 - ⊠ FIRE HYDRANT
 - ⊠ GAS METER
 - ⊠ IRRIGATION VALVE
 - ⊠ IRRIGATION VAULT
 - ⊠ LIGHT POLE
 - ⊠ MAILBOX
 - ⊠ POWER POLE
 - ⊠ SIGN
 - ⊠ SIGNAL BOX
 - ⊠ STRUCTURAL POLE
 - ⊠ STORM DRAIN MANHOLE
 - ⊠ TELEPHONE RISER
 - ⊠ TELEPHONE VAULT
 - ⊠ WASTE WATER MANHOLE
 - ⊠ WATER METER
 - ⊠ WATER VALVE
 - ▨ CONCRETE
 - ▨ GRAVEL
 - ▨ STRUCTURE
 - ▨ BRICK

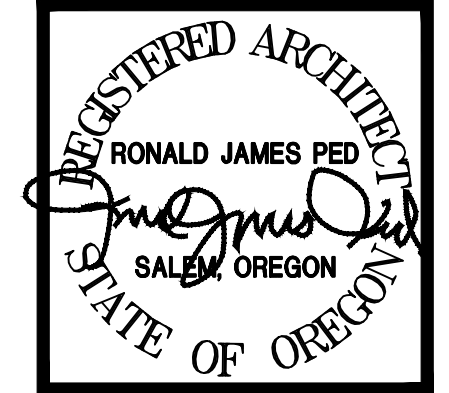
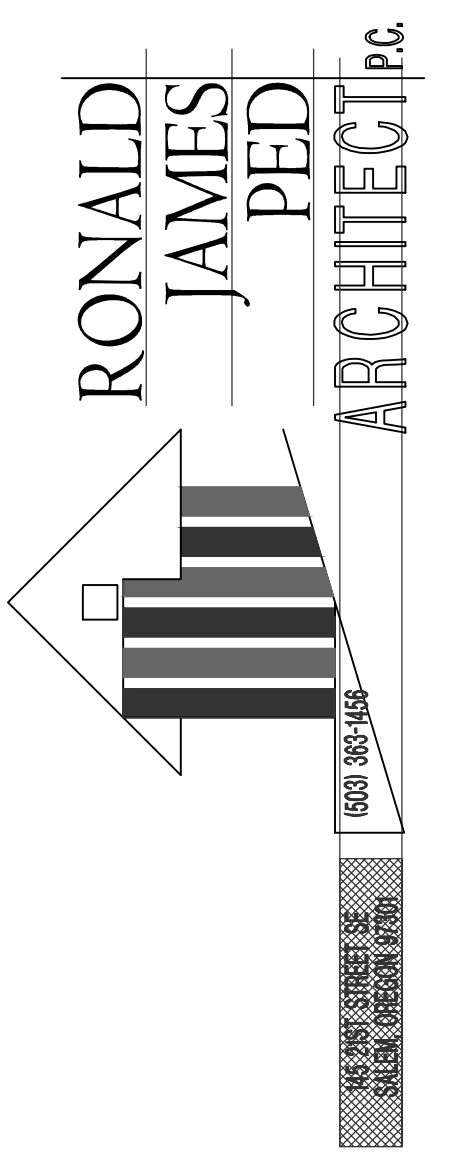

NEW OFFICE, RETAIL AND GAS STATION
 US MARKET
 2600 NEWBERG HIGHWAY WOODBURN OREGON

DATE: DEC. 1, 2020
 DRAWN: AK / KDG
 JOB NO. 1984

A1.2

LAST SAVED: Tue, 06 Feb 2024 - 10:57 am LOCATION: C:\Users\kevin\AppData\Local\Temp\AcPublish_2428\A1.1 Updated Site 2.1.24.dwg A1.3
PRINTED: Tue, 06 Feb 2024 - 11:40 am PRINTED BY: kevin

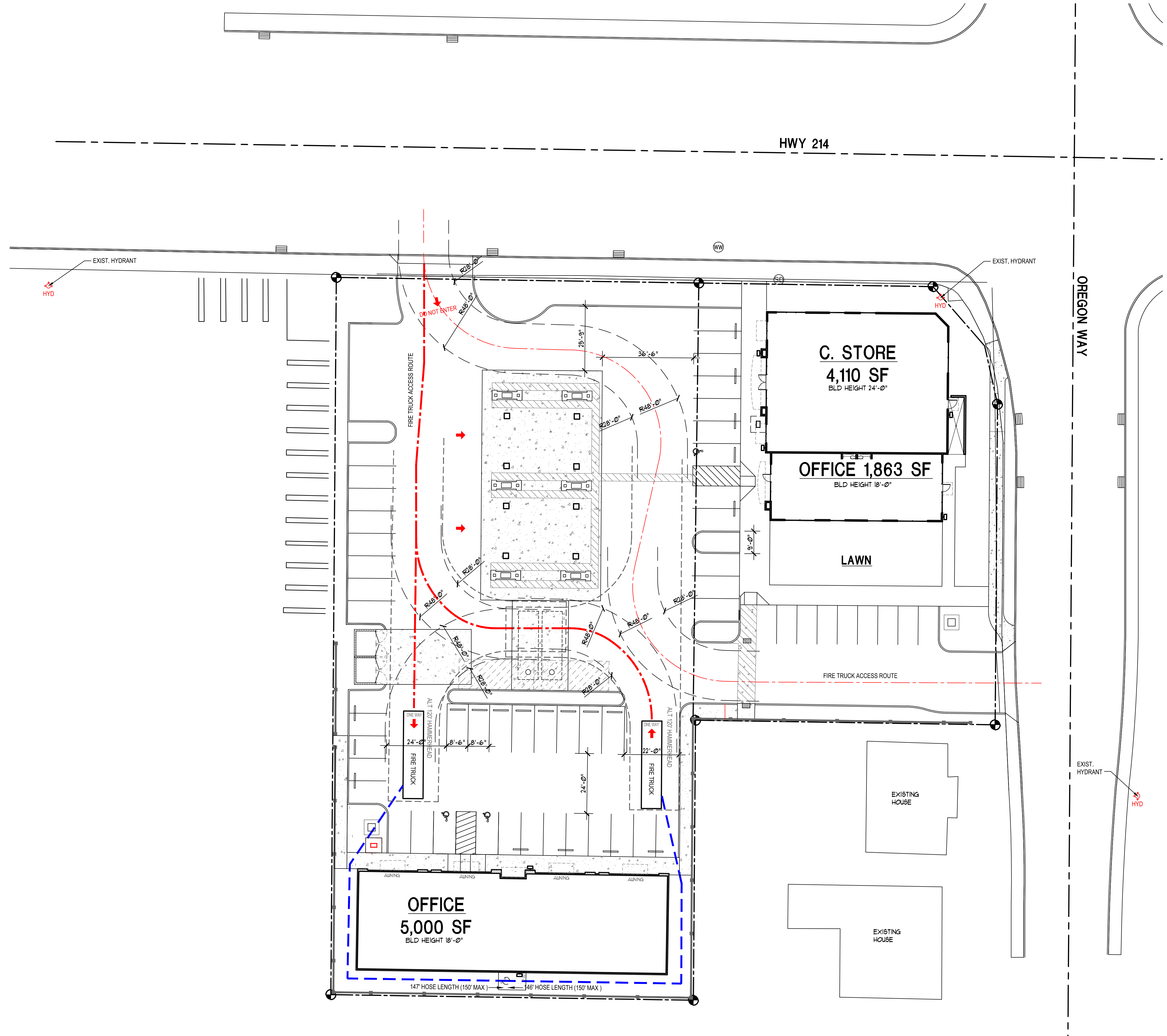

A FIRE ACCESS PLAN
SCALE: 1" = 20'
0 10' 20' 40'

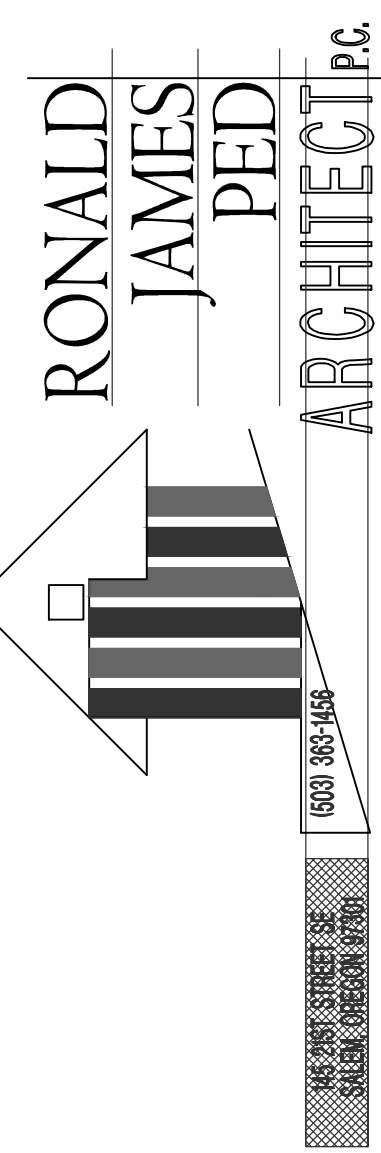
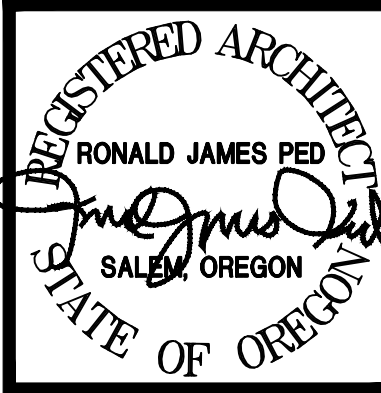

NEW OFFICE, RETAIL AND GAS STATION
US MARKET
2600 NEWBERG HIGHWAY WOODBURN OREGON

DATE: DEC. 1, 2020
DRAWN: AK / KDG
JOB NO. 1984

A1.3

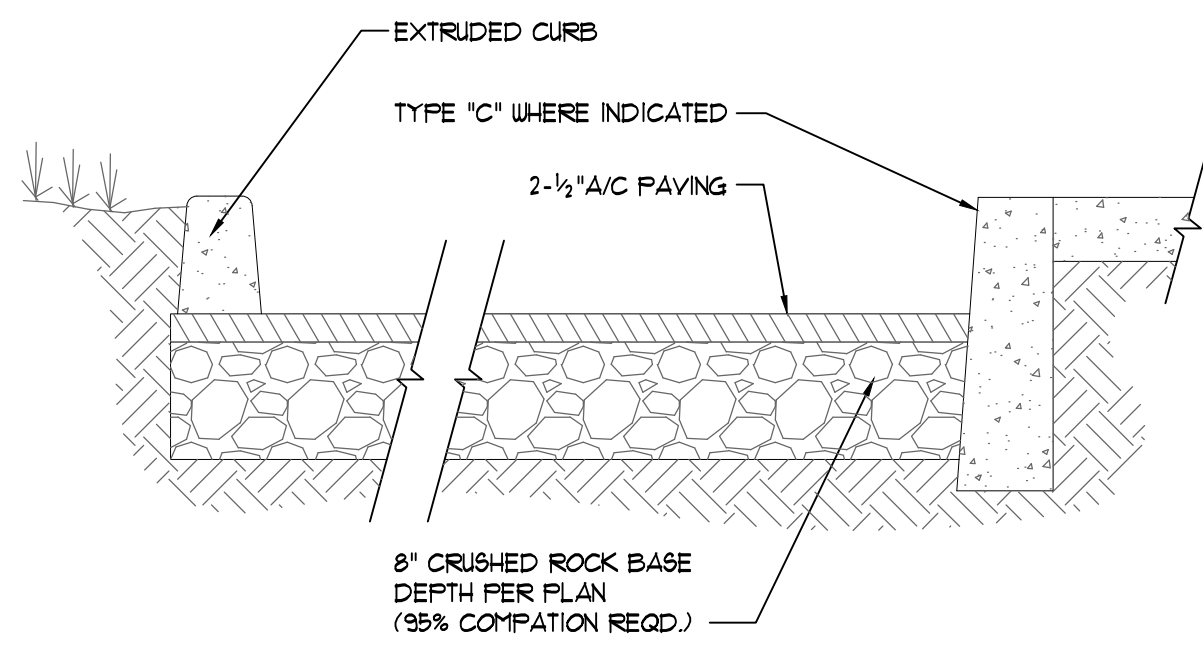

1 CURB DETAIL
SCALE: 1" = 1'-0"
M:\026\TEUK\5\0\ACPAV\025\0 ACPAV SECT 25 ON 6

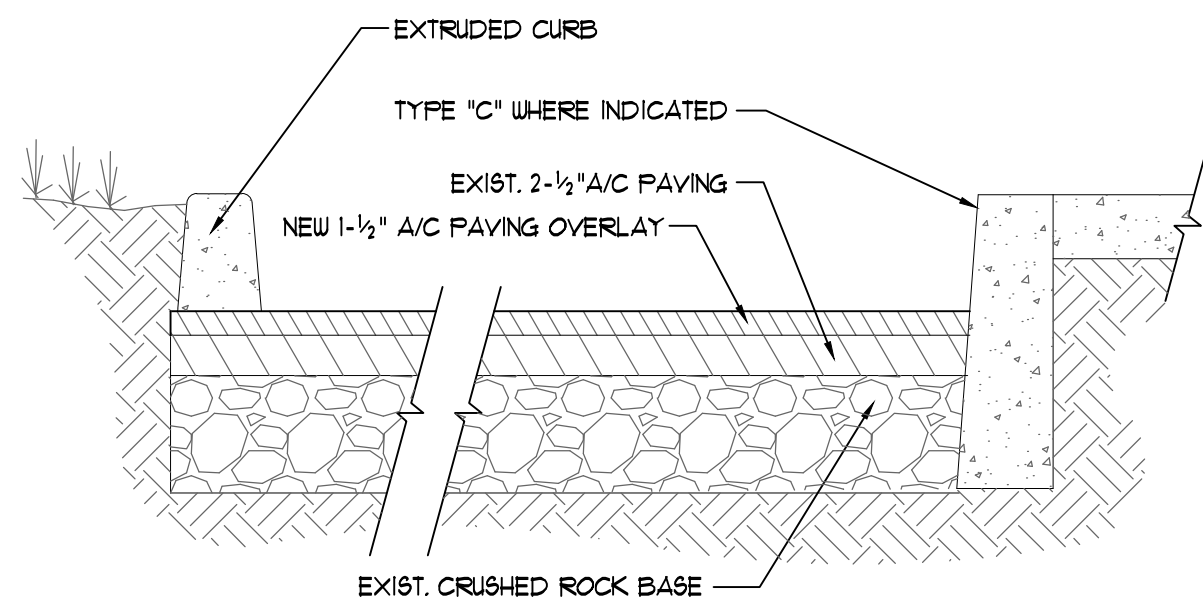

2 CURB DETAIL AT EXIST PAVING
SCALE: 1" = 1'-0"
M:\026\TEUK\5\0\ACPAV\025\0 ACPAV SECT 25 ON 6

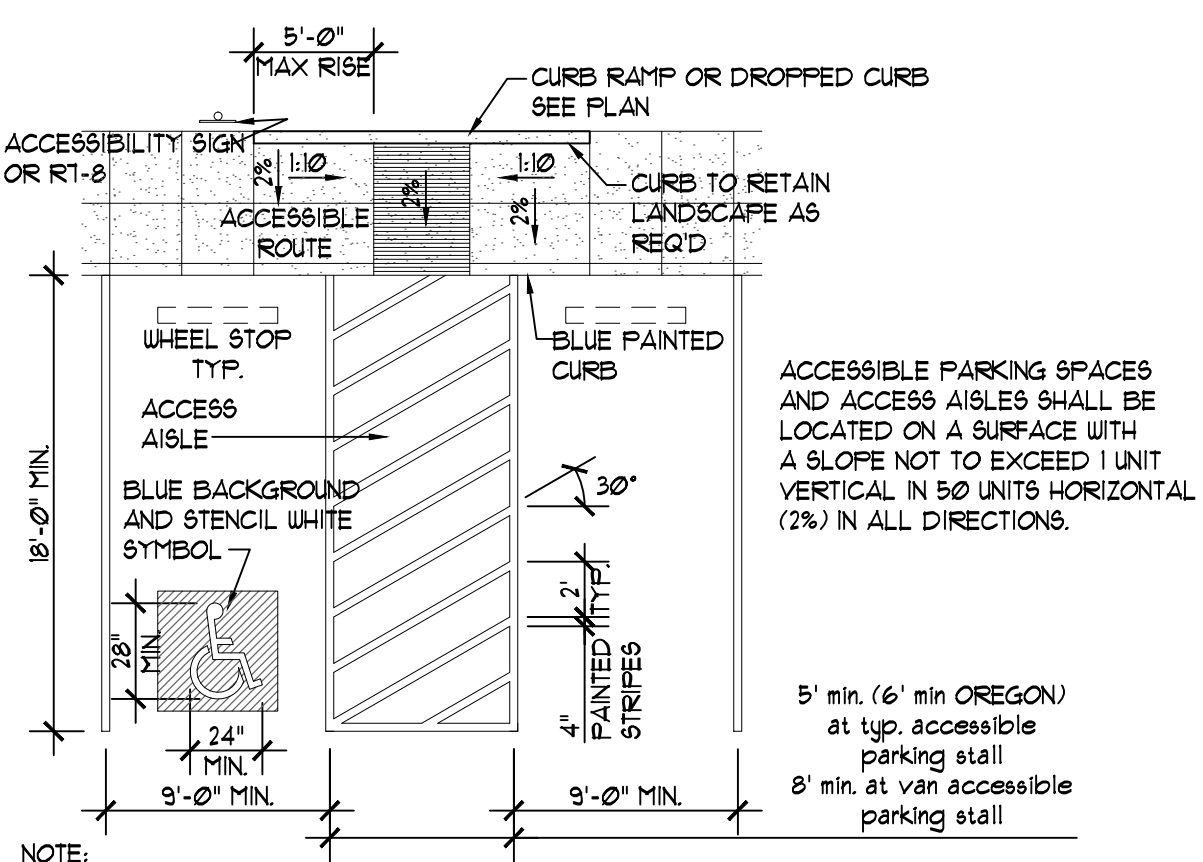

3 SINGLE DISABLED PARKING SPACE
WHITE STRIPING AND PAVEMENT STENCIL REQUIRED
SCALE: 1/8" = 1'-0"
M:\026\TEUK\5\0\MPKG\025\0 HG-05L

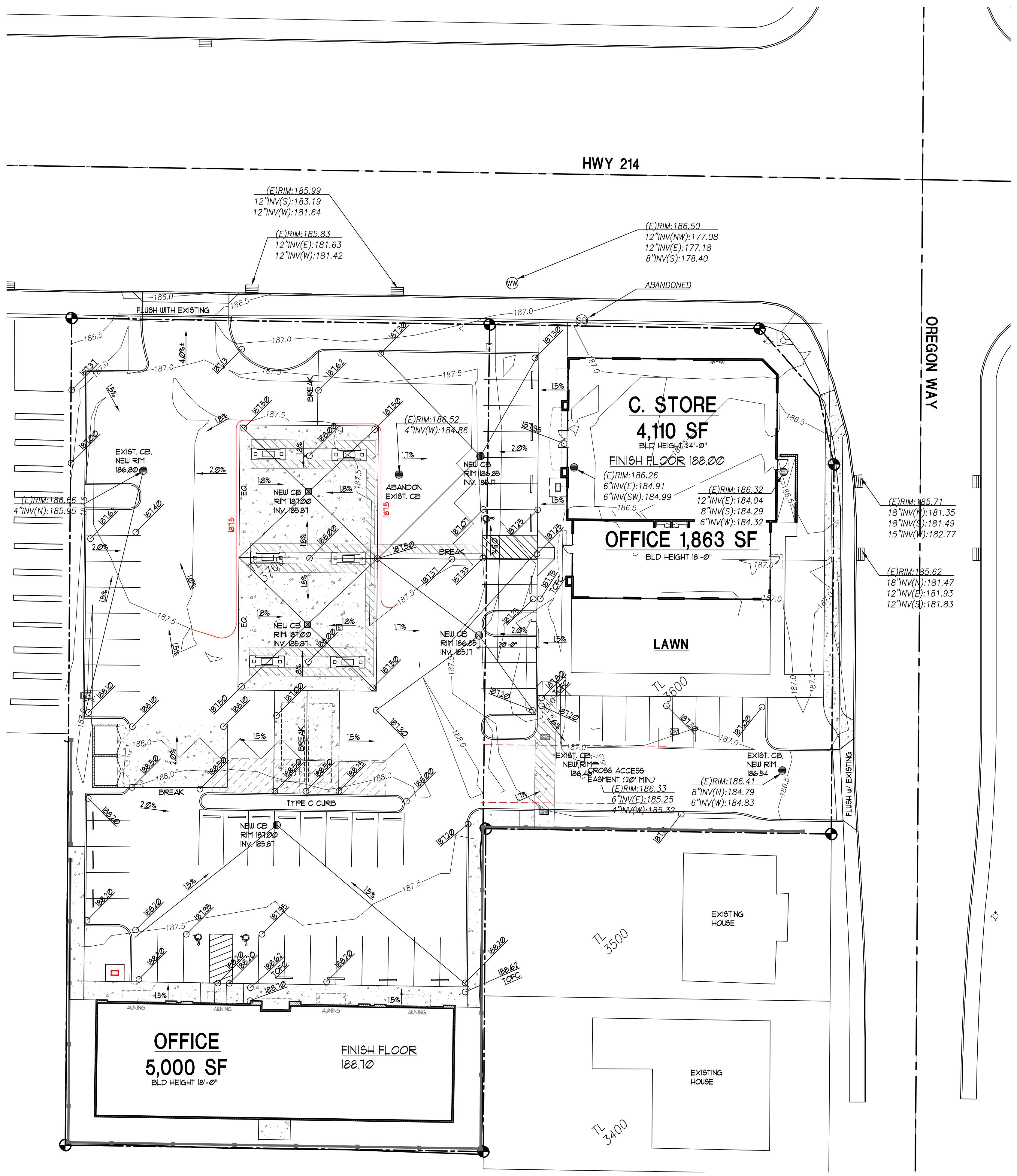

GRADING PLAN
SCALE: 1" = 20'
0 10 20 40

- LEGEND**
- PROPERTY LINE
 - ROW CENTER LINE
 - BUILDING WALL
 - BUILDING EAVE
 - 187.0--- CONTOUR LINE
 - EDGE OF ASPHALT
 - CURB
 - FENCE
 - E --- ELECTRIC LINE
 - G --- GAS LINE
 - S --- SIGNAL LINE
 - T --- TELEPHONE LINE
 - SS --- WASTE WATER LINE
 - W --- WATER LINE
 - AREA DRAIN
 - BOLLARD
 - ⊥ CLEANOUT
 - COMMUNICATION RISER
 - ▣ CATCH BASIN
 - ⊙ DECIDUOUS TREE
 - ⊙ CONIFEROUS TREE
 - DOWNSPOUT
 - ELECTRIC BOX
 - ELECTRIC VAULT
 - ⊙ FIRE HYDRANT
 - ⊙ GAS METER
 - ⊙ IRRIGATION VALVE
 - ▣ IRRIGATION VAULT
 - LIGHT POLE
 - MAILBOX
 - ⊙ POWER POLE
 - SIGN
 - SIGNAL BOX
 - STRUCTURAL POLE
 - ⊙ STORM DRAIN MANHOLE
 - TELEPHONE RISER
 - ▣ TELEPHONE VAULT
 - ⊙ WASTE WATER MANHOLE

RONALD JAMES PED ARCHITECT P.C.
 6500 985 1488

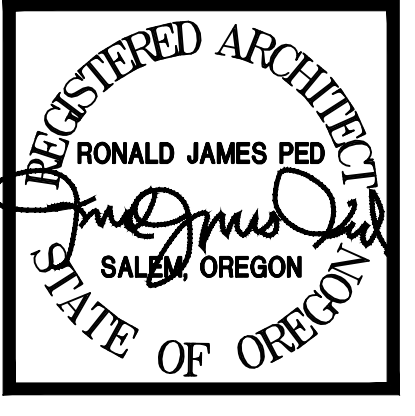

NEW OFFICE, RETAIL AND GAS STATION
US MARKET
 2600 NEWBERG HIGHWAY WOODBURN OREGON

DATE: DEC. 1, 2020
 DRAWN: AK / KDG
 JOB NO.: 1984

A1.3

LAST SAVED: Tue, 06 Feb 2024 - 10:57 am LOCATION: C:\Users\kevin\AppData\Local\Temp\AcPublish_2428\A1.1 Updated Site 2.1.24.dwg C1.1
 PRINTED: Tue, 06 Feb 2024 - 11:40 am PRINTED BY: kevin

- NOTES:
- ALL CASTINGS SHALL CONFORM TO ASTM A 48 (AASHTO M 105) FOR GRAY IRON CASTINGS, CLASS 30, OR (AASHTO M 192K CLASS 10) FOR CAST STEEL.
 - ROUNDS, FILLETS, TAPERS AND OTHER MINOR MODIFICATIONS TO THE DIMENSIONS SHOWN FOR CASTINGS MAY BE MADE TO CONFORM TO COMMON SHOP PRACTICES.
 - GRATES AND FRAMES MAY BE OF CAST IRON OR WELDED CONSTRUCTION, AT THE CONTRACTOR'S OPTION.
 - STEEL FOR WELDED GRATE & FRAME SHALL BE ASTM A-1 OR ASTM A-313.

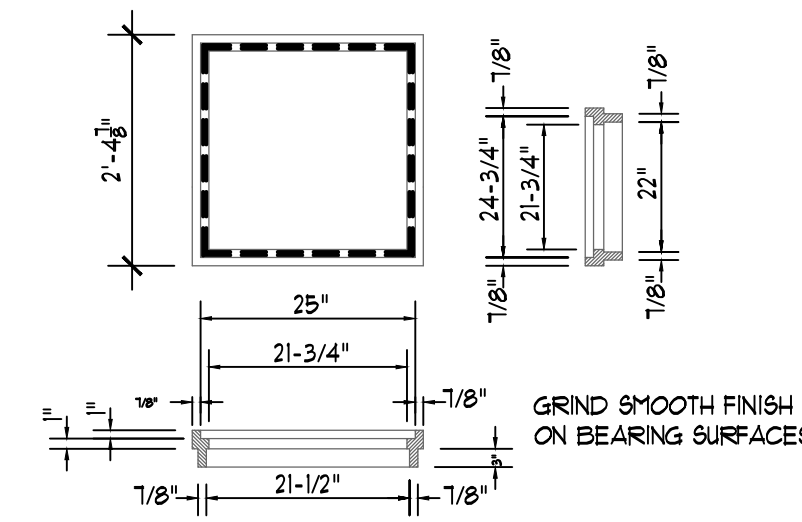
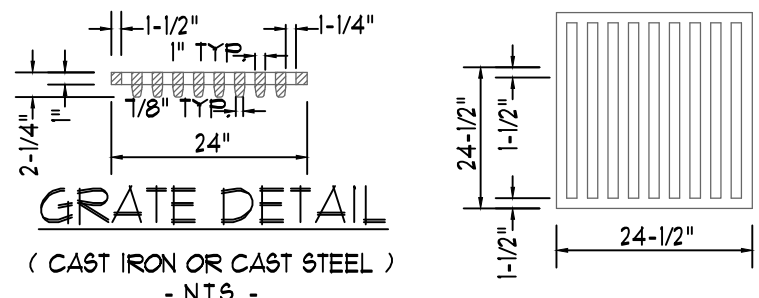

CATCH BASIN HAS GRATE (SEE DTL.) CATCH BASIN CLEANOUT HAS SOLID COVER (SEE NOTE NO. 4 BELOW).

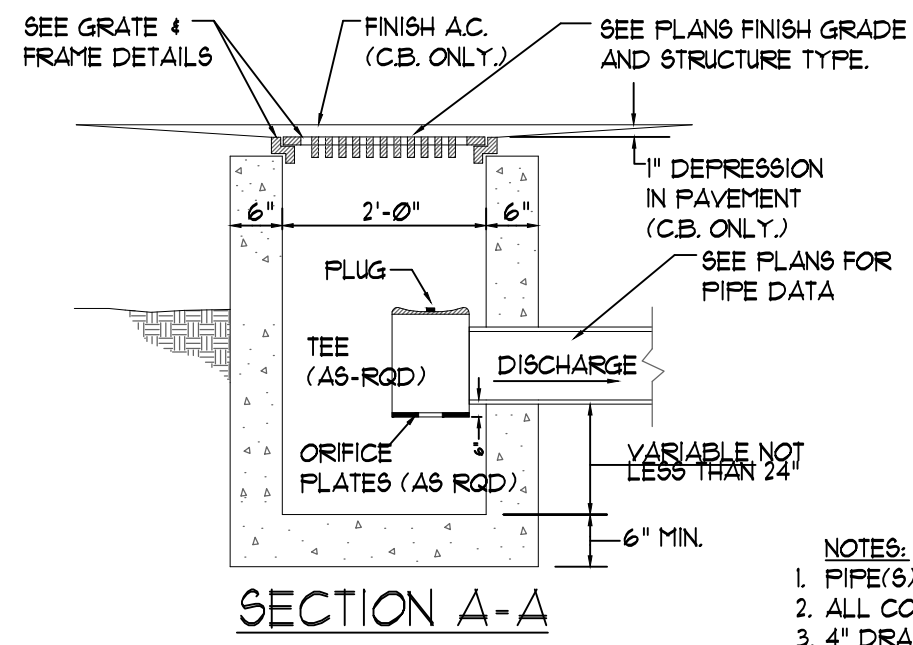

- NOTES:
- PIPE(S) CAN BE PLACED IN ANY WALL.
 - ALL CONCRETE TO BE 3300 P.S.I.
 - 4" DRAINS TO BE CONCRETE PIPE.
 - TO CONSTRUCT CATCHBASIN CLEANOUT - REPLACE GRATE WITH 1'-3 1/2" x 1'-11 1/2" STEEL PLATE 3/4" THICK DRILL 1" DIA. LIFT HOLE NEAR ONE END OF PLATE.

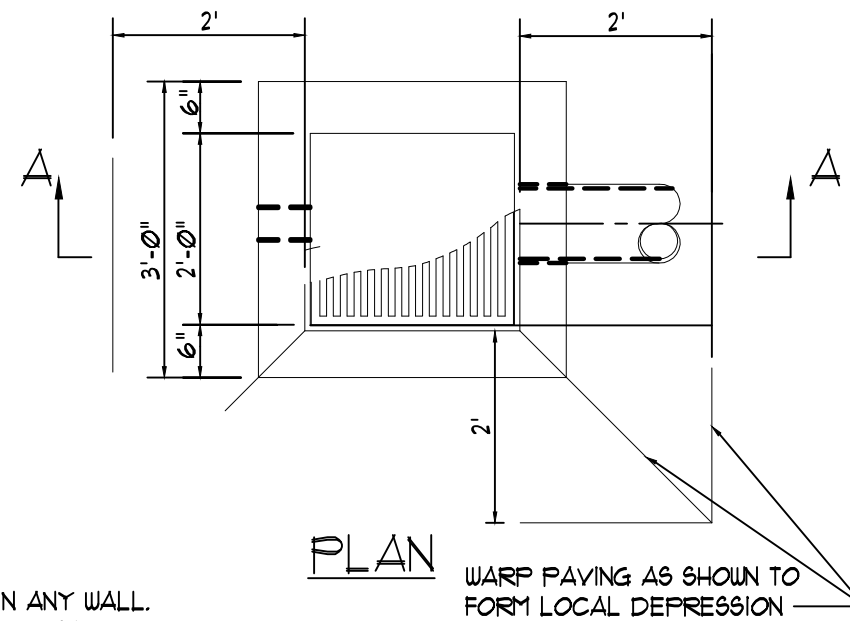

1 STANDARD CATCHBASIN AND CATCH BASIN CLEANOUT
SCALE: 1/2" = 1'-0"

LEGEND

---	PROPERTY LINE
---	ROW CENTER LINE
---	BUILDING WALL
---	BUILDING EAVE
---	CONTOUR LINE
---	EDGE OF ASPHALT
---	CURB
---	FENCE
---	ELECTRIC LINE
---	GAS LINE
---	SIGNAL LINE
---	TELEPHONE LINE
---	WASTE WATER LINE
---	WATER LINE
○	AREA DRAIN
○	BOLLARD
○	CLEANOUT
□	COMMUNICATION RISER
□	CATCH BASIN
○	DECIDUOUS TREE
○	CONIFEROUS TREE
○	DOWNSPOUT
□	ELECTRIC BOX
□	ELECTRIC VAULT
○	FIRE HYDRANT
○	GAS METER
○	IRRIGATION VALVE
□	IRRIGATION VAULT
○	LIGHT POLE
○	MAILBOX
○	POWER POLE
○	SIGN
□	SIGNAL BOX
○	STRUCTURAL POLE
○	STORM DRAIN MANHOLE
□	TELEPHONE RISER
□	TELEPHONE VAULT
○	WASTE WATER MANHOLE

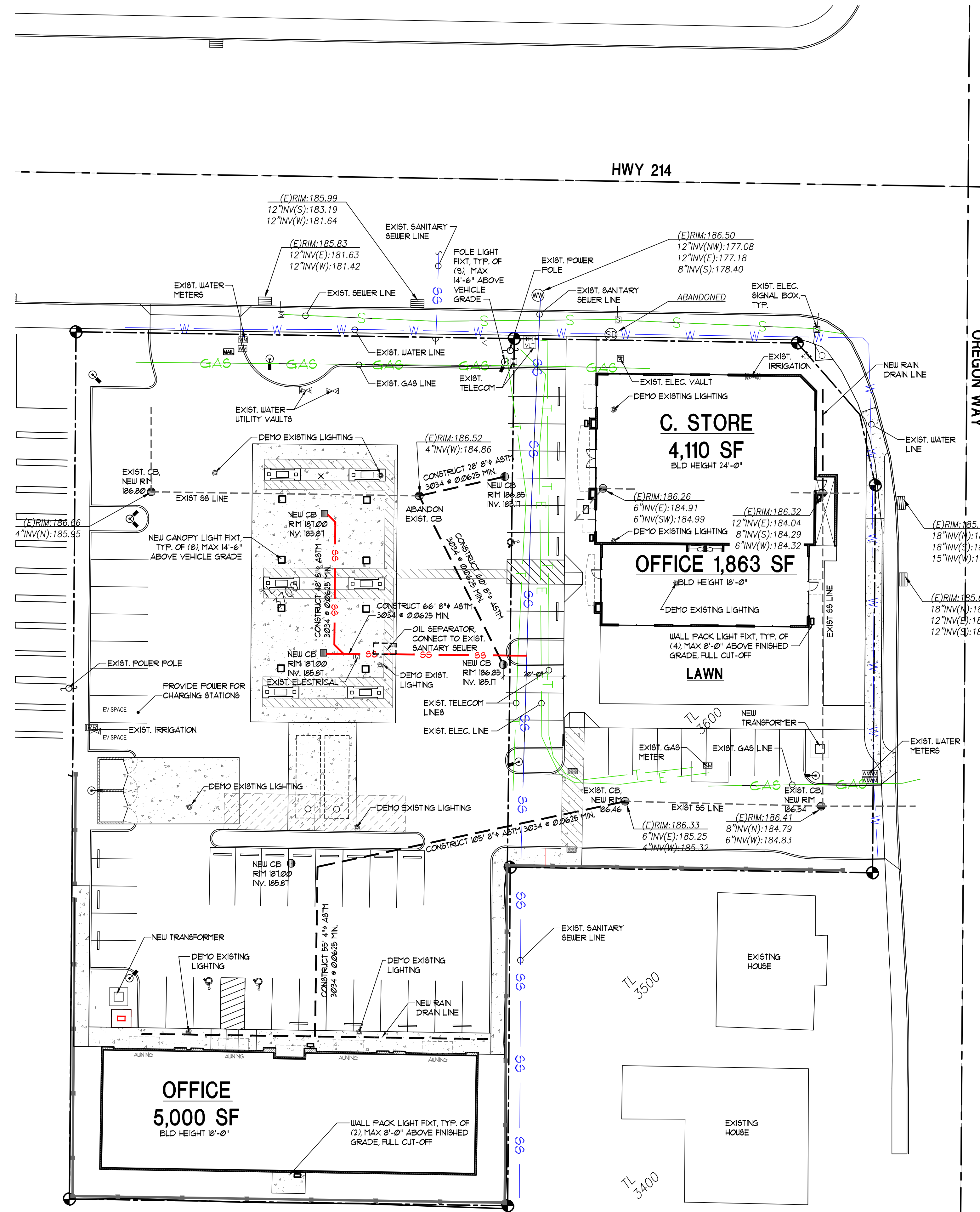

RONALD JAMES PED ARCHITECT P.C.
600 9th Street, SE
Salem, Oregon 97302
503.585.1988



NEW OFFICE, RETAIL AND GAS STATION
US MARKET
2600 NEWBERG HIGHWAY WOODBURN OREGON

DATE: DEC. 1, 2020
DRAWN: AK / KDG
JOB NO.: 1984

A1.3

LAST SAVED: Tue, 06 Feb 2024 - 10:57 am LOCATION: C:\Users\kevin\AppData\Local\Temp\AcPublish_2428.A1.1 Updated Site 2.1.24.dwg C1.2
PRINTED BY: kevin Tue, 06 Feb 2024 - 11:40 am

LAST SAVED: Tue, 06 Feb 2024 - 10:57 am LOCATION: C:\Users\kevin\AppData\Local\Temp\AcPublish_2428\A1.1 Updated Site 2.1.24.dwg E1.1
 PRINTED: Tue, 06 Feb 2024 - 11:40 am PRINTED BY: kevin

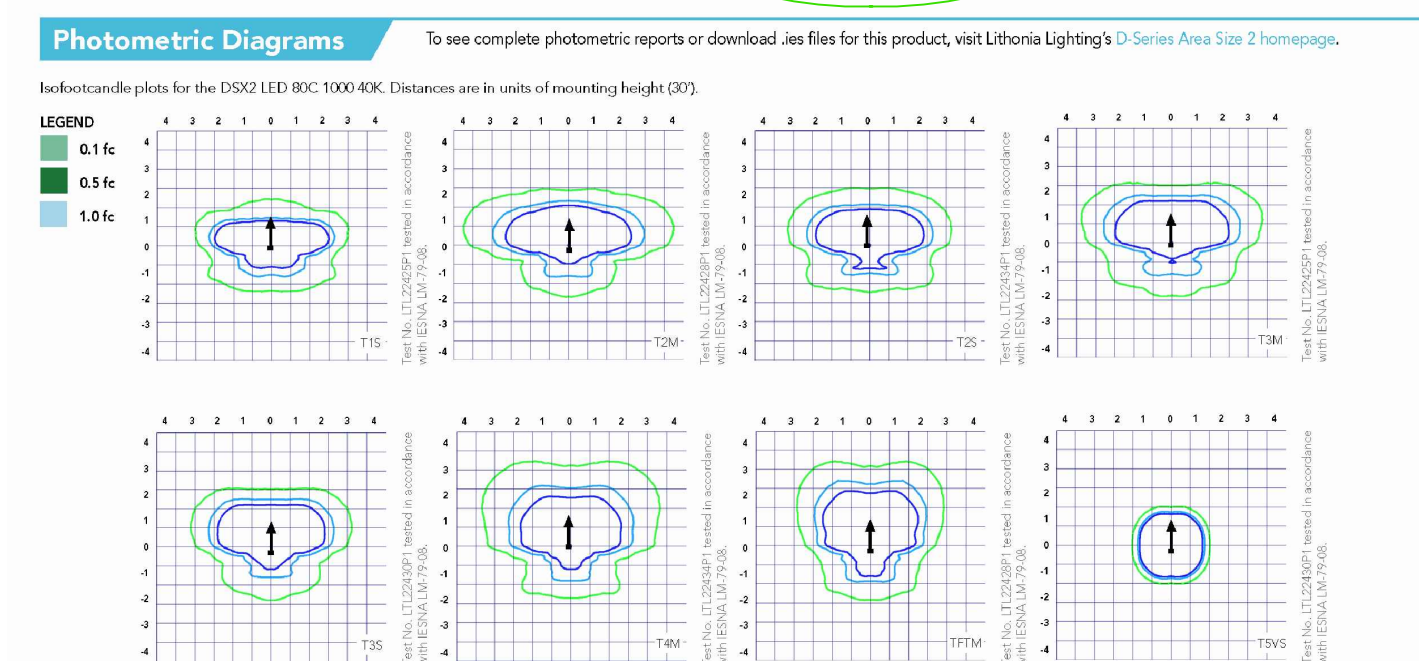
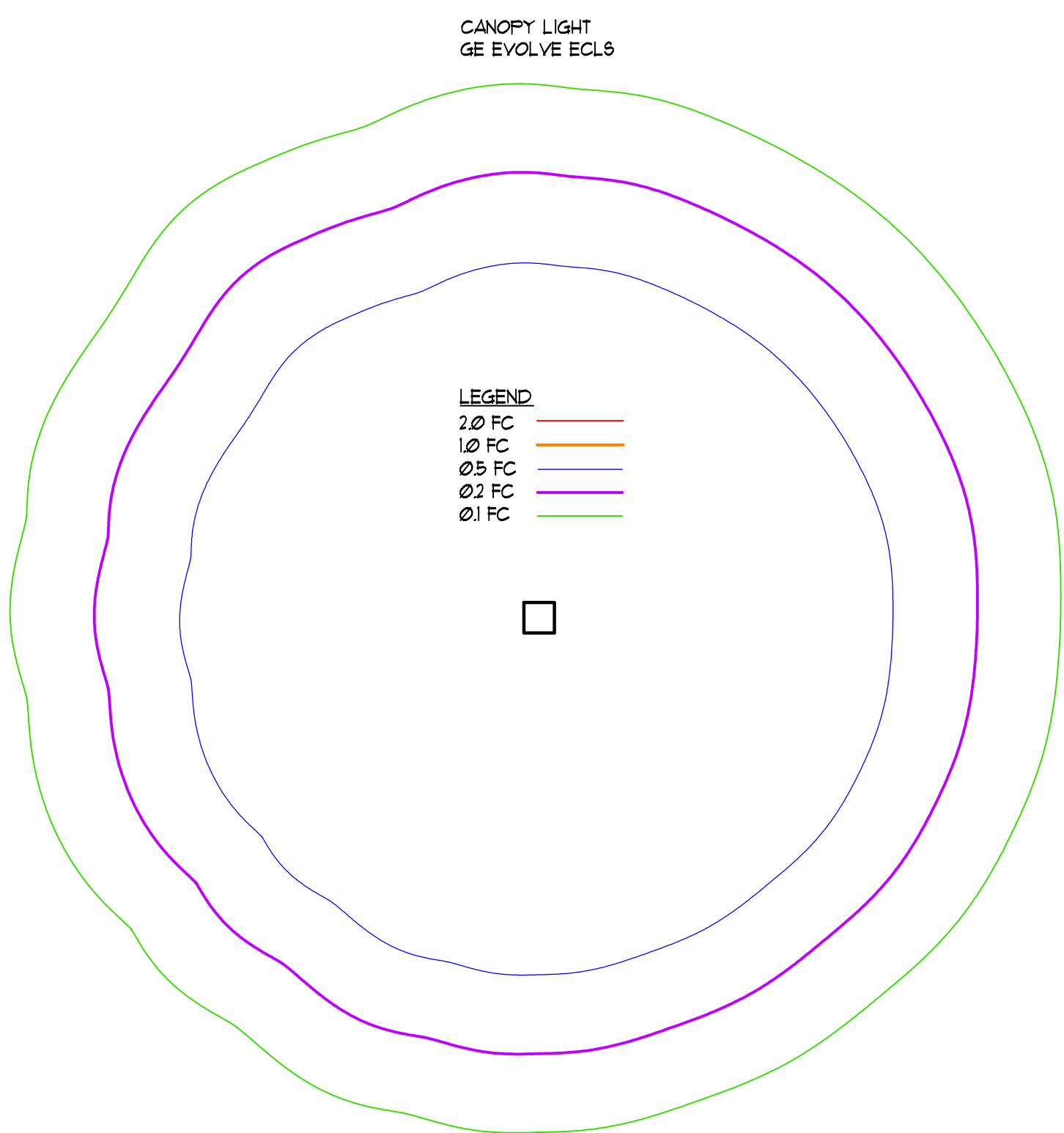
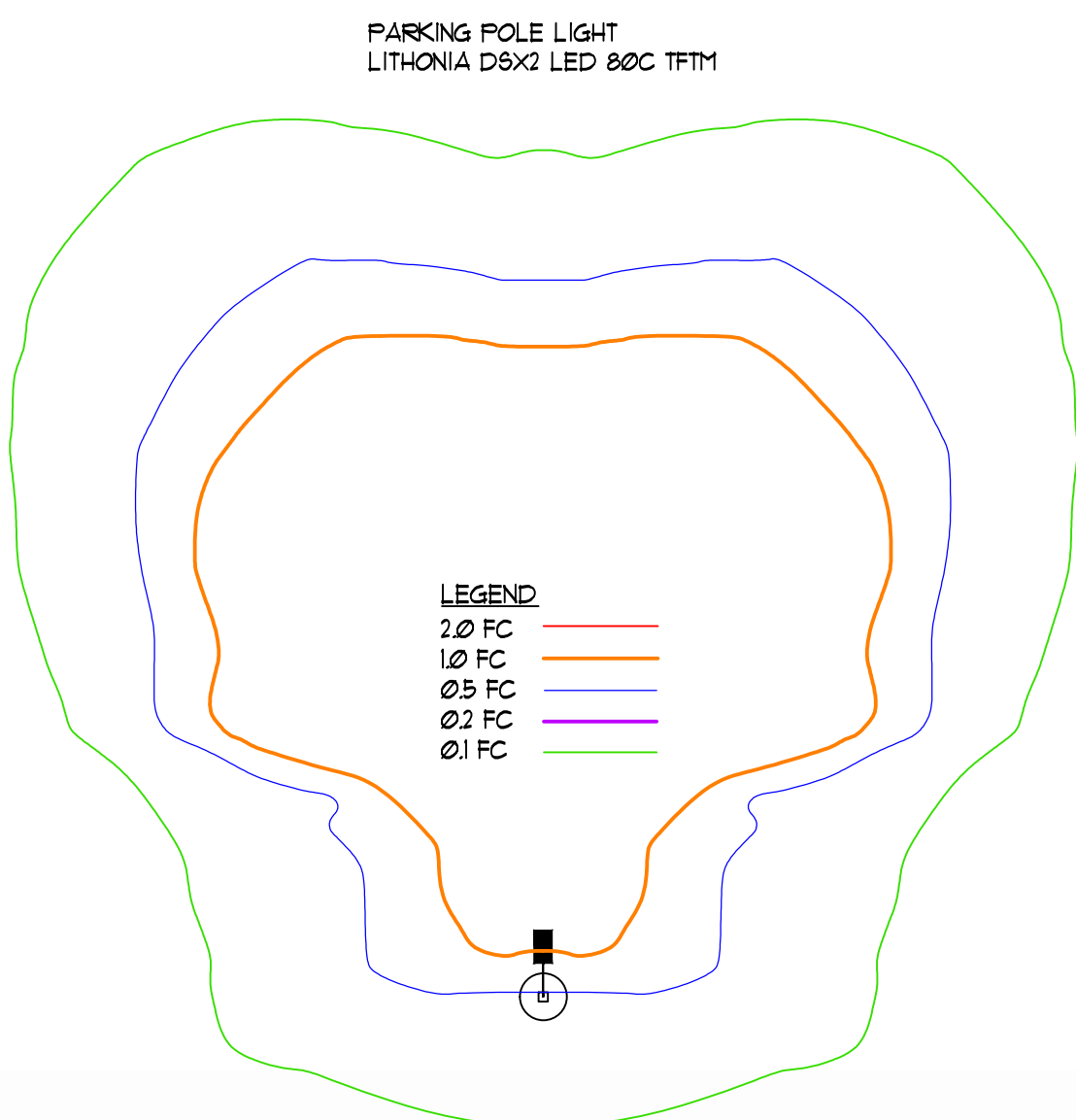
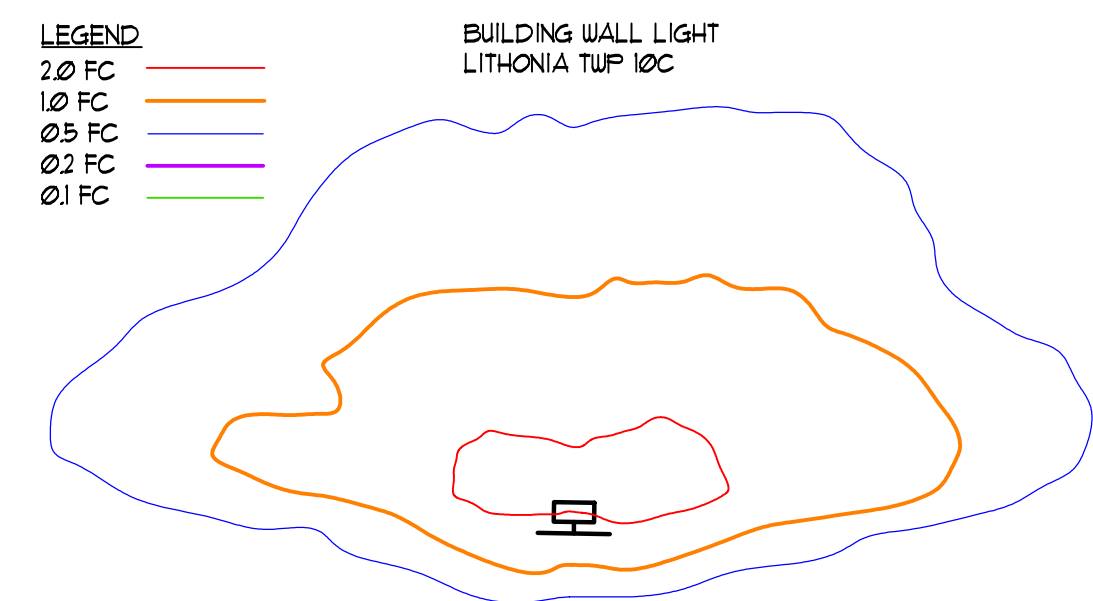
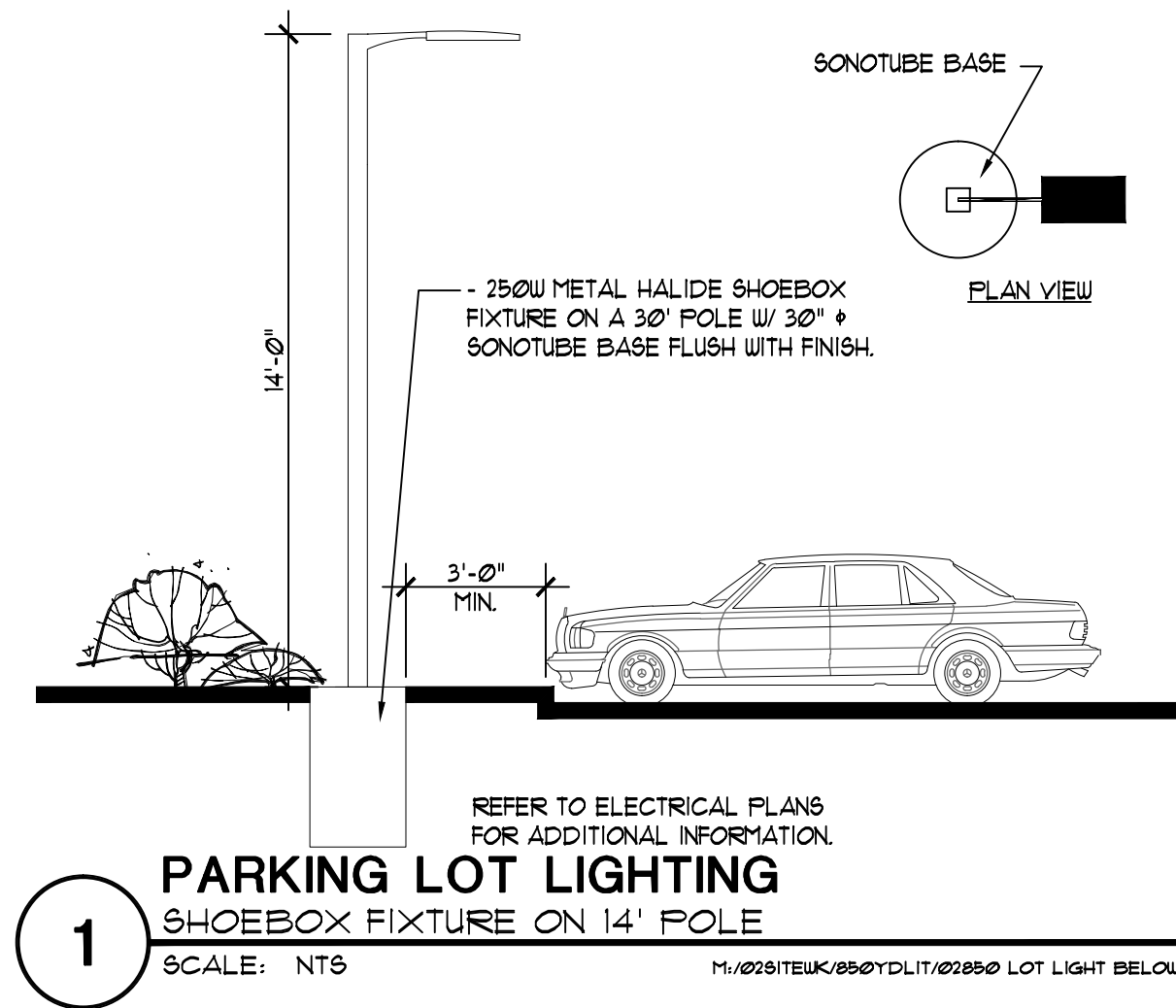

LIGHTING SCHEDULE

- PARKING POLE LIGHT
LITHONIA DSX2 LED 80C TFM
- CANOPY LIGHT
LITHONIA CAY LED P0
- BUILDING WALL LIGHT
EATON Lumark WP WAL-PACK w/ FULL CUTOFF
- EXISTING PARKING POLE LIGHT

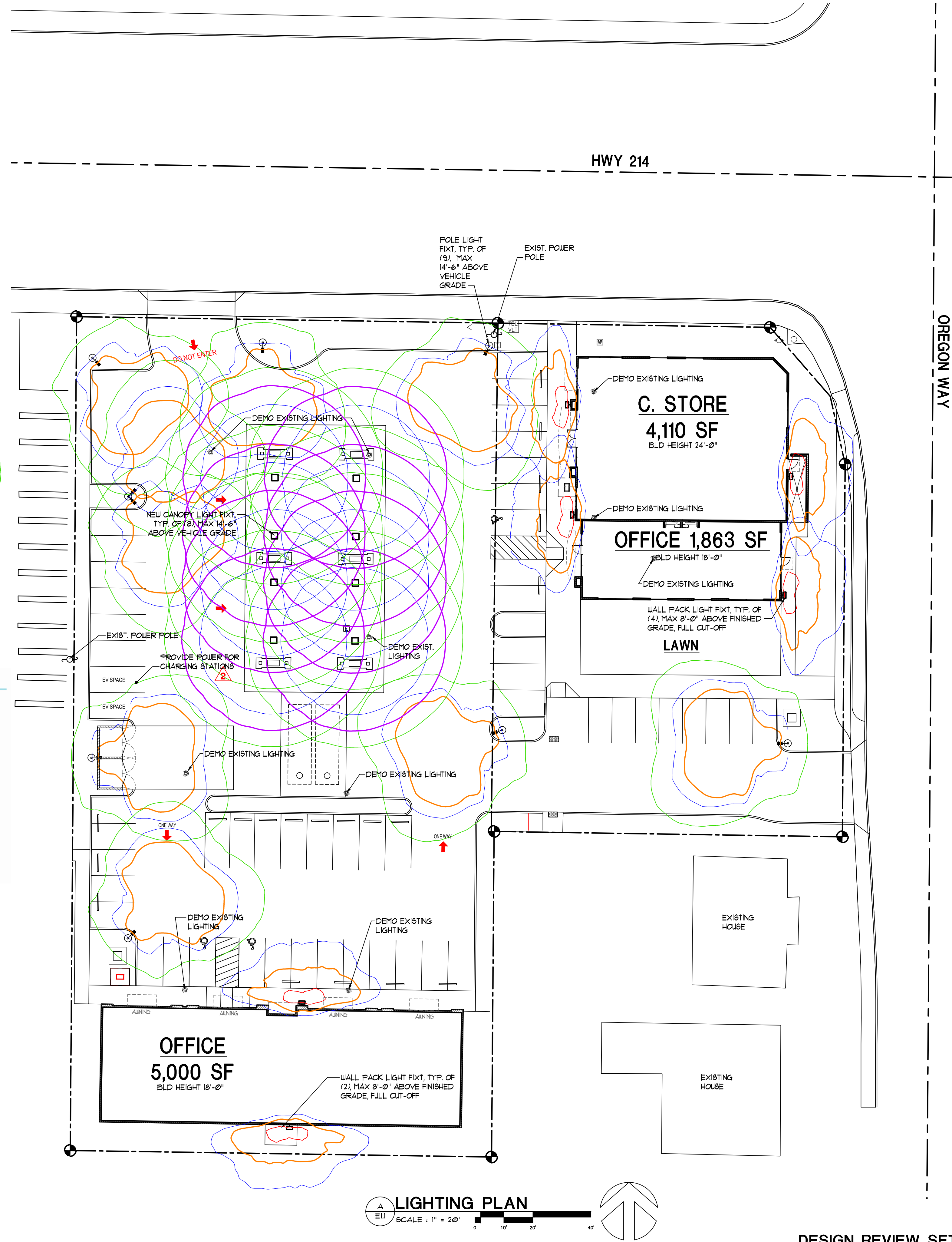

SITE SUMMARY

PROPERTY SIZE	= 62,120 SF. (1.43 AC)
TOTAL BUILDING AREA	= 10,913 SF.
TOTAL PAVED AREA	= 41,011 SF.
TOTAL LANDSCAPE AREA	= 10,136 SF. (24.1%)

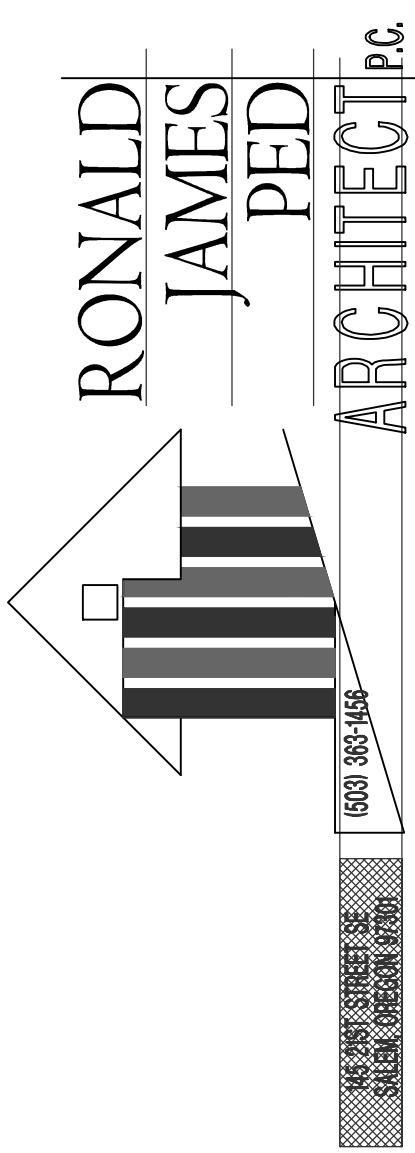

PLANT LIST

STREET TREES	COMMON NAME/BOTANICAL NAME	SIZE	COMMENTS	COUNT
T-ASH	ASH, RAYWOOD FRAXINUS OXYCARPA 'RAYWOOD'	7'-8" LARGE	2" CALIPER 10 FU	
T-LIN	LINDEN TILIA CORDATA 'HALA'	7'-8" LARGE	2" CALIPER 10 FU	
T-MAP ARM	ARMSTRONG MAPLE, ACER RUBRUM 'ARMSTRONG'	7'-8" MEDIUM	2" CALIPER 10 FU	
T-MAP RED	ACER RUBRUM/RED MAPLE October Glory	7'-8" MEDIUM	2" CALIPER 10 FU	
T-DOUG FIR	DOUGLAS FIR / Pseudotsuga menziesii	LARGE	2" CALIPER 10 FU	
ORNAMENTAL TREES	COMMON NAME/BOTANICAL NAME	SIZE	COMMENTS	
T-JAPO	CRYPTOMERIA JAPONICA 'ELEGANS'	7'-8"	2" MIN CALIPER 5 FU	
T-TAMA	CRYPTOMERIA JAPONICA 'TAISHO TAMA' (TAISHO TAMA JAPANESE CEDAR)	4'-6"	2" MIN CALIPER 5 FU	
T-BLA	CRYPTOMERIA JAPONICA 'BLACK DRAGON'	4'-6"	2" MIN CALIPER 5 FU	
T-MAP VINE	VINE MAPLE/ACER circinatum	7'-8"	2" MIN CALIPER 2 FU	
T-CRAB	CRABAPPLE/MALUS 'AMERICAN BEAUTY'	7'-8"	2" MIN CALIPER 2 FU	
T-CRY	CRYPTOMERIA JAPONICA 'SEKKEN-SUGI'	6'	2" MIN CALIPER 5 FU	
T-CUP	CUPRESSUS SEMPERVIRENS ITALIAN CYPRESS 'STRICTA'	6'	2" MIN CALIPER 5 FU	
T-CHA	CHAMAECYPARIS OBUSA HINOKI FALSE CYPRESS 'GRACILIS'	6'	2" MIN CALIPER 5 FU	

SIZE	SHRUBS	COMMON NAME/BOTANICAL NAME	COMMENTS
1 gal. 3 gal.	S-HYB.	HYBISCUS/HIBISCUS Syriacus ROSE OF SHARON 'MINERVA' 'AZURRI SATIN'	1 FU 1 gal / 2 FU 3 gal
	S-STR.	DEUTZIA x hybridis 'STRAWBERRY FIELDS'	1 FU 1 gal / 2 FU 3 gal
	S-ABE.	ABELIA grandiflora 'EDWARD GOUCHER' (EVERGREEN)	1 FU 1 gal / 2 FU 3 gal
	S-VIBD.	VIBURNUM Japonicum (EVERGREEN)	1 FU 1 gal / 2 FU 3 gal
	S-PIE.	PIERIS Japonicum 'LILLY-OF-THE-VALLEY' (EVERGREEN/SHADE)	1 FU 1 gal / 2 FU 3 gal
	S-AUC.	AUCUBA JAPONICA JAPANESE AUCUBA (EVERGREEN/SHADE)	1 FU 1 gal / 2 FU 3 gal
	S-VIB.	VIBURNUM ELLIPTICUM COMMON VIBURNUM	1 FU 1 gal / 2 FU 3 gal
	S-CURR.	RED-FLOWERING CURRANT/Ribes sanguineum	1 FU 1 gal / 2 FU 3 gal

GROUND COVER	BOTANICAL NAME/COMMON NAME	SIZE	COMMENTS
G-PHL.	PHLOX SUBULATA CREEPING PHLOX	1 gal.	24" SPACING 1 FU
G-VIN.	VINCA MAJOR PERIWINKLE	1 gal.	24" SPACING 1 FU

1 PLANT LIST

SCALE: N/A

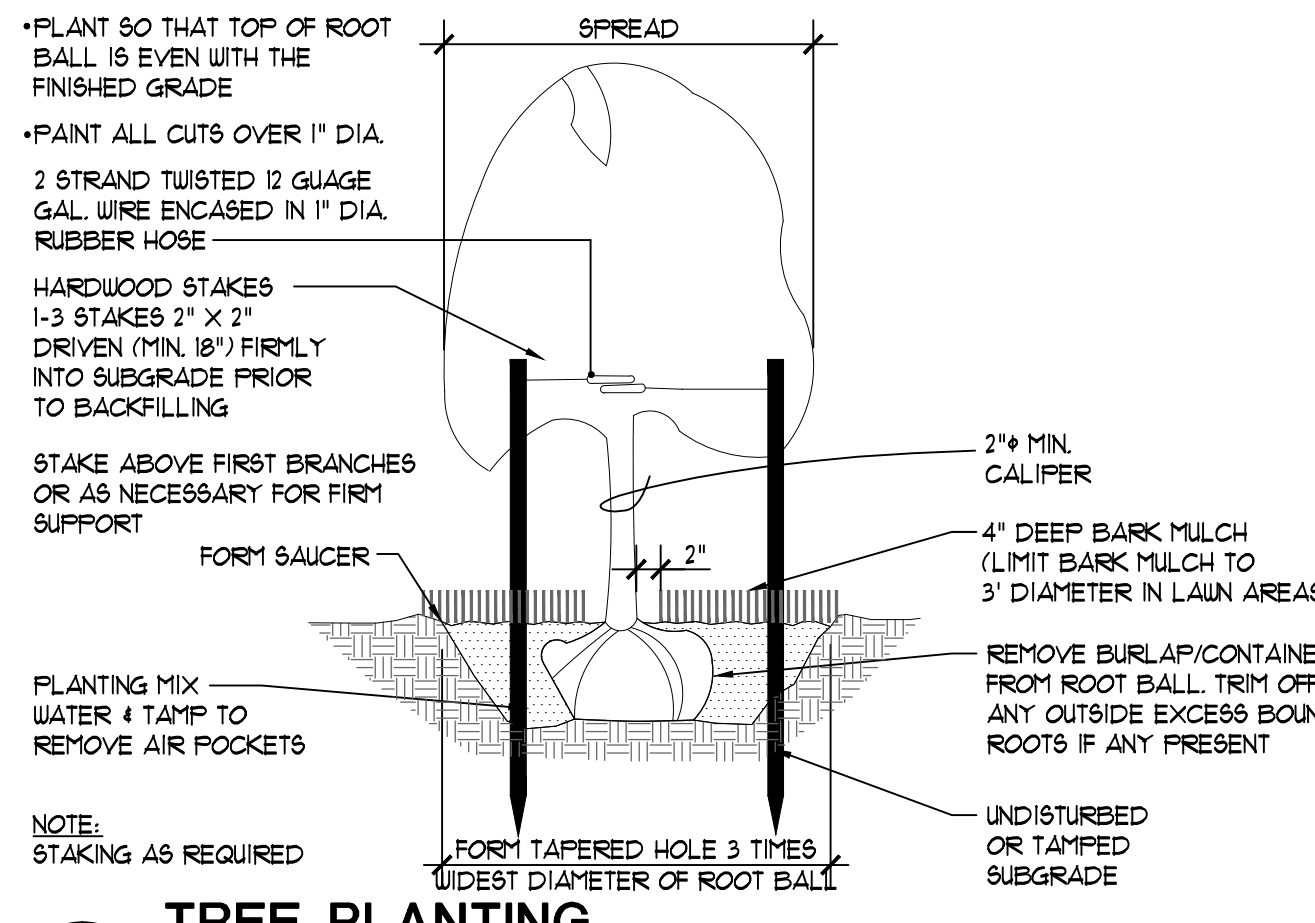

2 TREE PLANTING VERTICAL STAKES

SCALE: NTS

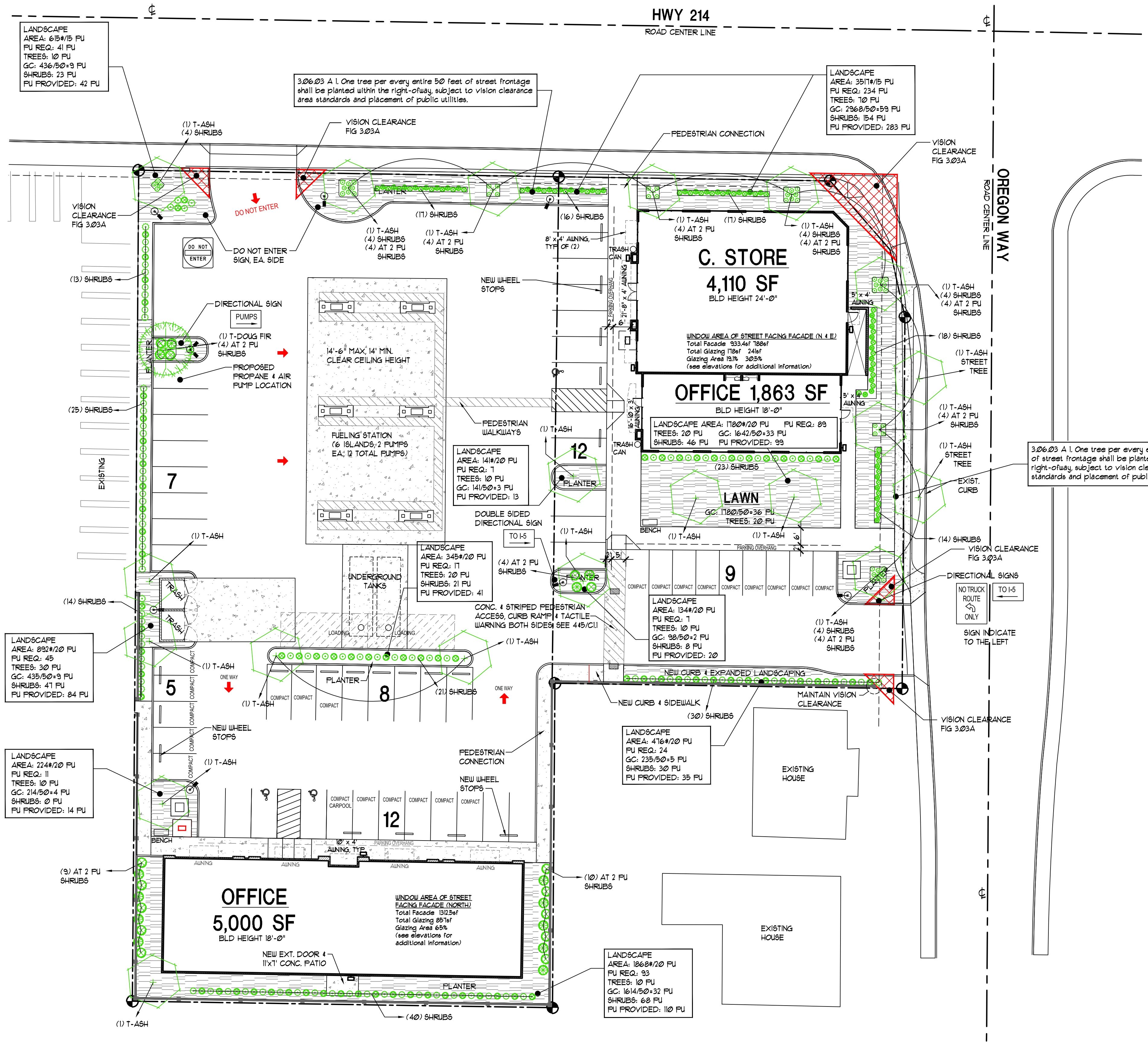

LANDSCAPE PLAN

SCALE: 1" = 20'

LAST SAVED: Tue, 06 Feb 2024 - 10:57 am LOCATION: C:\Users\kevin\AppData\Local\Temp\AcPublish_2428\A.1 Updated Site 2.1.24.dwg L1.1
 PRINTED BY: kevin

NEW OFFICE, RETAIL AND GAS STATION
US MARKET
 2600 NEWBERG HIGHWAY WOODBURN OREGON

DATE: DEC. 1 2020
 DRAWN: AK / KDS
 JOB NO. 1984

L1.1

CONVENIENCE STORE

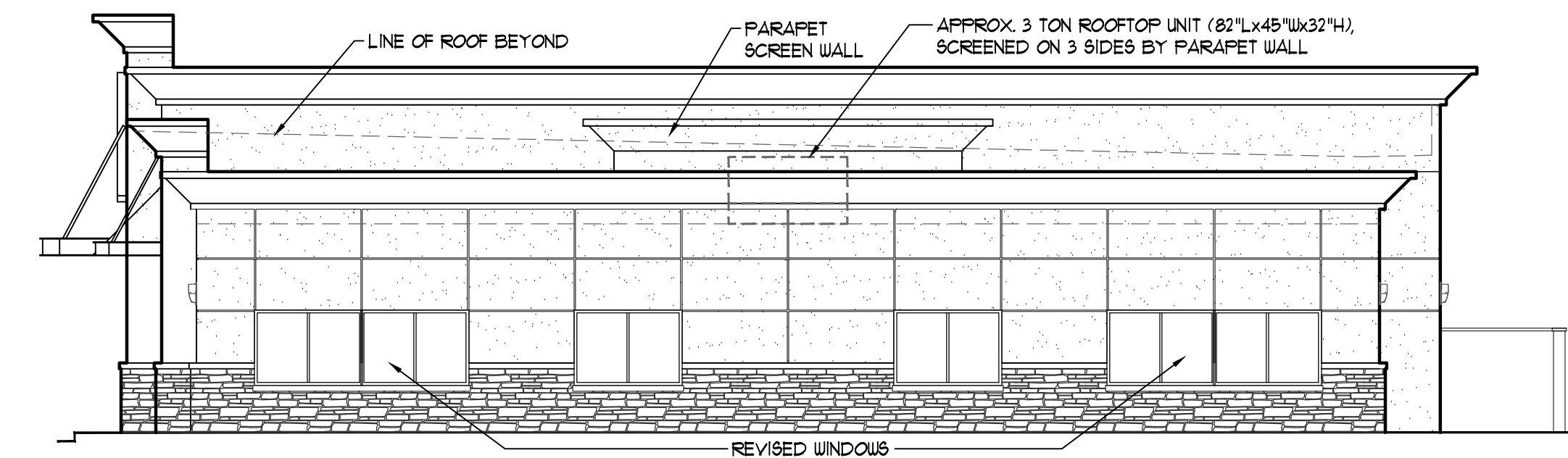

A CONVENIENCE STORE - SOUTH ELEVATION
SCALE: 1/8" = 1'-0"

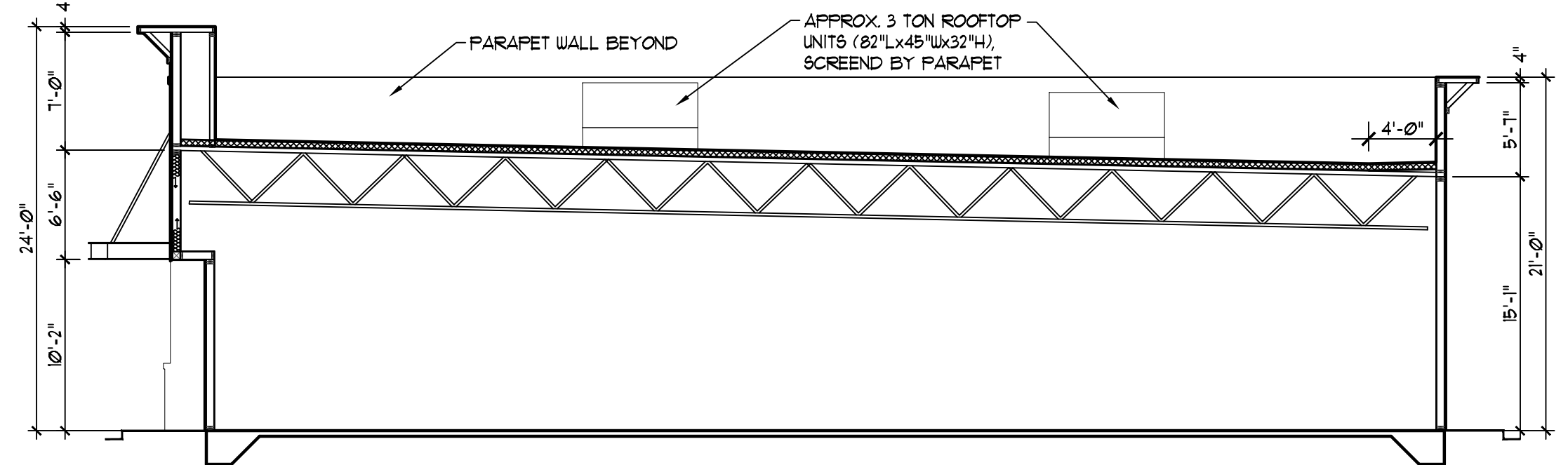

B CONVENIENCE STORE - CROSS SECTION
SCALE: 1/8" = 1'-0"

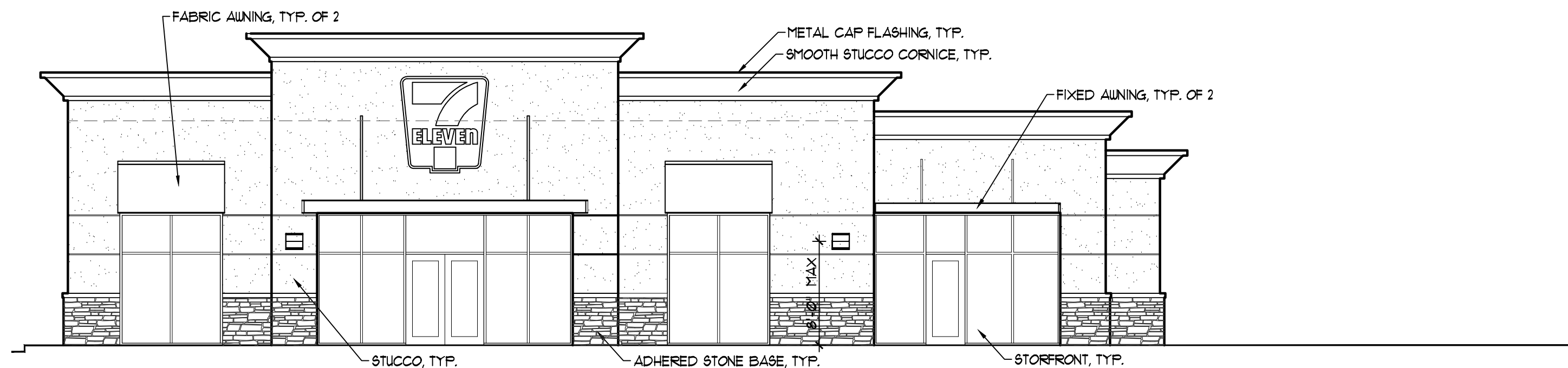

C CONVENIENCE STORE - WEST ELEVATION
SCALE: 1/8" = 1'-0"

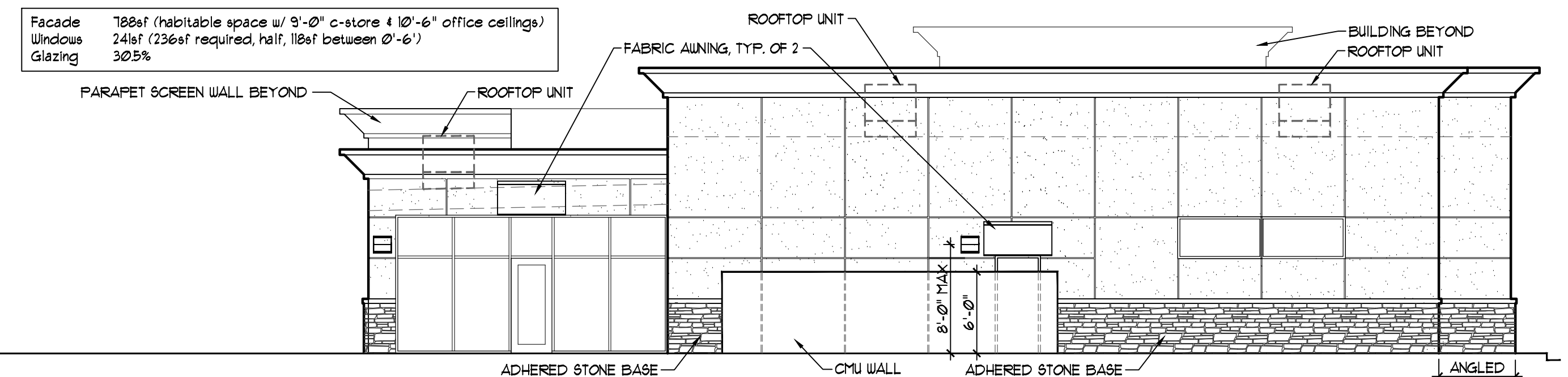

D CONVENIENCE STORE - EAST ELEVATION
SCALE: 1/8" = 1'-0"

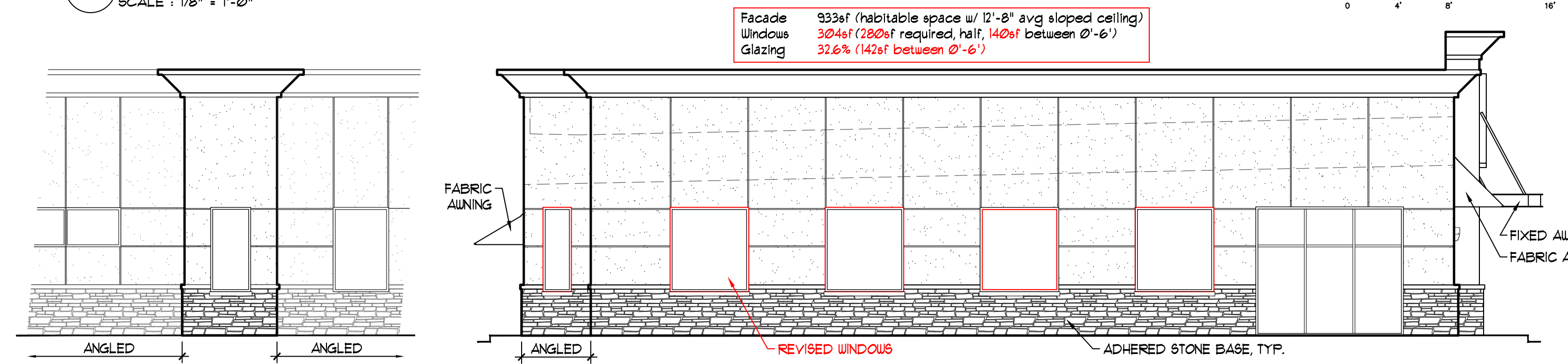

E ANGLED WALL
SCALE: 1/8" = 1'-0"

F CONVENIENCE STORE - NORTH ELEVATION
SCALE: 1/8" = 1'-0"

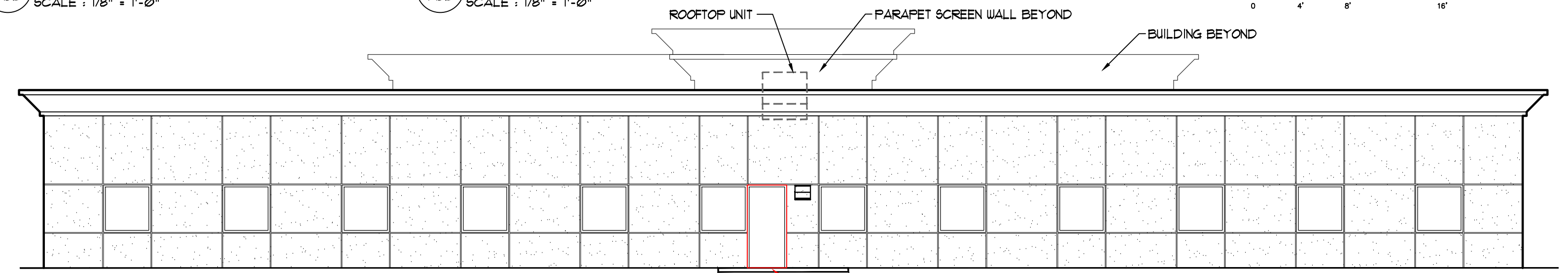

G OFFICE BUILDING - SOUTH ELEVATION
SCALE: 1/8" = 1'-0"

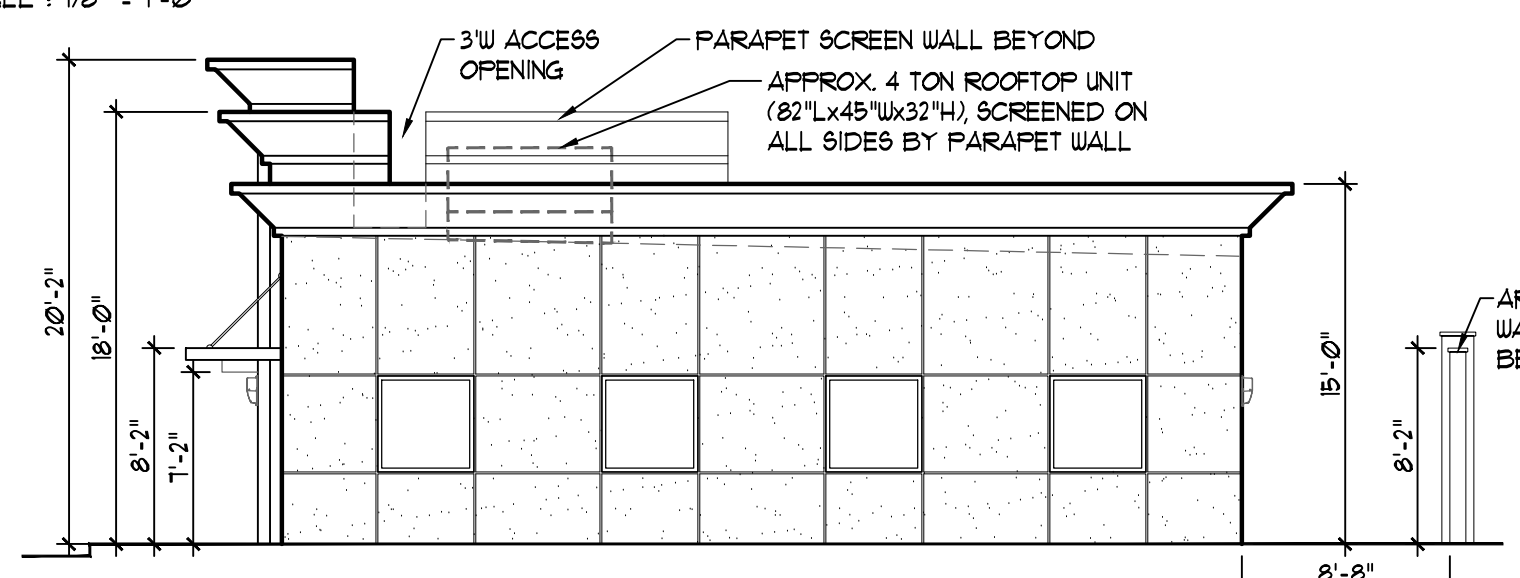

I OFFICE BLDG - WEST ELEV.
SCALE: 1/8" = 1'-0"



OFFICE BUILDING

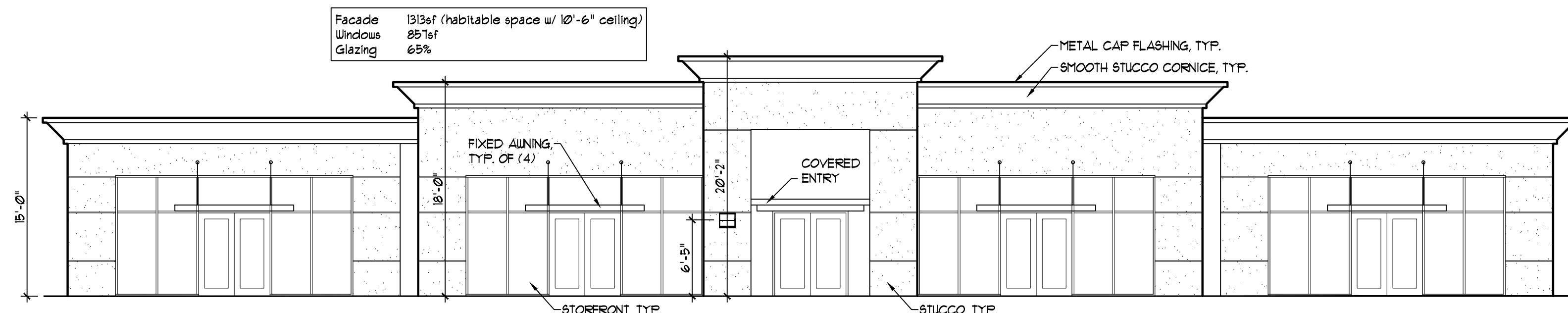

H OFFICE BUILDING - NORTH ELEVATION
SCALE: 1/8" = 1'-0"

RONALD JAMES PED
ARCHITECT P.C.
1600 983-458



NEW OFFICE, RETAIL AND GAS STATION
US MARKET
2600 NEWBERG HIGHWAY WOODBURN OREGON

DATE: DEC. 1, 2020
DRAWN: AK / KDB
JOB NO.: 1984

A3.1

LAST SAVED: Mon, 05 Feb 2024 - 02:45 pm
LOCATION: C:\Users\kevin\AppData\Local\Temp\AcPublish_24228\A3.1_1.20.22.dwg
PRINTED BY: kevin