

CONTRACT DOCUMENTS

For the Construction of

SIXTH ST. SANITARY SEWER REPLACEMENT

Project No. 2020-013-08

Bid No. 2021-04

For The

CITY OF WOODBURN

Woodburn, Oregon

December 2020

For Information regarding this project contact:

**Pete Gauthier P.E.
Project Engineer
Engineering Division
City of Woodburn
503.982.2429**

**CONTRACT AND BONDS
FOR SANITARY SEWER
CONSTRUCTION**

SIXTH ST. SANITARY SEWER REPLACEMENT

**PROJECT No. 2020-013-08
BID NO. 2021-04**

**CITY OF WOODBURN
PUBLIC WORKS DEPARTMENT
WOODBURN, OREGON**

ERIC SWENSON	MAYOR
DEBBIE CABRALES	COUNCIL WARD 1
ALI SWANSON	COUNCIL WARD 2
ROBERT CARNEY	COUNCIL WARD 3
SHARON SCHAUB	COUNCIL WARD 4
MARY BETH CORNWELL	COUNCIL WARD 5
BENITO PUENTE JR.	COUNCIL WARD 6

CITY OF WOODBURN
PUBLIC WORKS DEPT. – ENGINEERING DIV.

**BID PACKAGE
AND
CONSTRUCTION SPECIFICATIONS
FOR
SIXTH ST. SANITARY SEWER REPLACEMENT**

TABLE OF CONTENTS

PART I BID DOCUMENTS

INVITATION TO BID
INSTRUCTIONS TO BIDDERS

PART II BID FORMS

CERTIFICATION PAGE
FORM OF PROPOSAL
FIRST TIER SUBCONTRACTOR'S DISCLOSURE FORM
BID SUBMITTAL CHECKLIST

PART III CONTRACT FORMS

SAMPLE – CERTIFICATE OF LIABILITY INSURANCE
SAMPLE - CONSTRUCTION AGREEMENT
SAMPLE - NOTICE OF AWARD
PERFORMANCE BOND
PAYMENT BOND
MAINTENANCE AND WARRANTY BOND
SAMPLE – NOTICE TO PROCEED

PART IV TECHNICAL SPECIFICATIONS

OREGON STANDARD SPECIFICATIONS FOR CONSTRUCTION, 2018 EDITION
GENERAL CONDITIONS
SPECIAL PROVISIONS
APPENDIX B

PART V PLANS

DRAWINGS

G-1 COVER SHEET
G-2 CONSTRUCTION NOTES
C-1 PLAN AND PROFILE 700 BLOCK
C-2 PLAN AND PROFILE 900 BLOCK
5-12 DETAILS

CITY OF WOODBURN
SIXTH ST. SANITARY SEWER REPLACEMENT

PART I
BID PREPARATION DOCUMENTS

INVITATION TO BID
INSTRUCTIONS TO BIDDERS

INVITATION TO BID

CITY OF WOODBURN

SIXTH STREET SANITARY SEWER REPLACEMENT

PROJECT No. 2020-013-08

BID No. 2021-04

Sealed bids for the **Sixth Street Sanitary Sewer Replacement Project** will be received by the City of Woodburn, OR at City Hall Annex, 190 Garfield St. until **2:00 PM, Thursday, January 14, 2021** and will thereafter be publicly opened and read.

Proposals shall be addressed to the City Engineer, City of Woodburn, 190 Garfield St., Woodburn, OR 97071. Bids shall be submitted in a plain sealed envelope bearing the Bidder's name, the name of the project and the date and time of the Bid opening, and shall be clearly marked "**Bid No. 2021-04**", and Bidders shall indicate on the Form of Proposal that "***Bidder will comply with the provisions of Chapter 279C.800 through 279C.870, Oregon Revised Statutes***".

DESCRIPTION OF THE PROPOSED WORK:

The major part of the work will include: Installing two (2) manholes, approximately 365' of 6" SS pipe, connect four (4) existing service laterals, connecting the new sewer to existing manholes in two places and restoration work.

Plans and specifications may be examined on or after **December 16, 2020** at the City Engineer's Office, 190 Garfield Street, Woodburn, OR and on line at <http://www.ci.woodburn.or.us/?q=blog-categories/bids-and-rfps> . Copies of the Contract Documents may be obtained from the City Engineer's Office upon deposit of a non-refundable fee of fifty dollars (\$50.00) for each set. Additionally, electronic plan sets are available for viewing and downloading on the Engineering Division's website at: <http://www.ci.woodburn.or.us/?q=blog-categories/bids-and-rfps> and/or have been downloaded by the following plan centers.

*DJC Plan Center – Portland, OR
Contractor's Plan Center – Clackamas, OR
Salem Contractor's Exchange – Salem, OR*

Bidders must be pre-qualified in accordance with the laws of the State of Oregon. Completed pre-qualification forms or proof of pre-qualification shall conform to the Special Provisions. Only bids from pre-qualified Bidders will be opened.

No bid for a construction contract shall be received or considered unless the bidder is registered with the Construction Contractors Board (CCB). The Contractor and every Subcontractor must have a Public Works Bond filed with the CCB before starting work on the project.

Bidders on this project need not be licensed for asbestos handling pursuant to ORS 468A.720. Each bidder must indicate on the bid form whether they are a resident or nonresident bidder as defined in ORS 279A.120(b).

All proposals shall be made on the proposal forms. All proposals shall be accompanied by a Bid Bond, equal to ten percent (10%) of the total bid. Bid Bond shall be forfeited to the City if the Contractor fails to execute the contract within 7-days after acceptance of the bid and award of the Contract.

Pursuant to ORS 279C.370, bidders on public works projects with a contract value of \$100,000 or more are required to disclose, 2-hours after bid opening, the bidders first-tier subcontractors. The bidder shall provide the information as required on City of Woodburn first-tier disclosure form, provided in the contract documents.

At the discretion of the Project Manager Addenda(um) and Contract clarifications shall either be posted on the City, Engineering Division website and/or delivered to Plan Holders via email. Potential Bidders should check the website on a daily basis the last week before the Bid Opening date. Website can be found at <http://www.ci.woodburn.or.us/?q=blog-categories/bids-and-rfps>. Addenda must be signed and submitted with the Proposal to be considered a responsive bid offer.

Contract award is expected to be made by the City Council on **February 8, 2021** the City of Woodburn reserves the right to reject any and all bids not in compliance with prescribed bidding procedures and requirements, and may reject for good cause any and all bids upon a finding of the Agency if it is in the public interest to do so. The three (3) lowest bidders may not withdraw or modify his bid prior to the lapse of 35-days after the bid opening.

For further information on this project please contact:

Pete Gauthier P.E., Project Engineer

P 503.980.2429

F 503.982.5242

pete.gauthier@ci.woodburn.or.us

Heather Pierson
City Recorder
City of Woodburn, OR 97071

INSTRUCTIONS TO BIDDERS
BID #2021-04

1. GENERAL:

- A. SPECIFICATIONS – The Specifications that is applicable to the Work on this Project is the 2018 edition of the “Oregon Standard Specifications for Construction” and as modified by Special Provisions.
- B. This is a formal procure. Faxed bids will not be accepted.
- C. Bidding requirements and obligations shall comply and conform to Part 00100 of the General Conditions of the Standard Specifications or as modified by the Special Provisions or herein.

2. SECURING CONTRACT DOCUMENTS:

- A. Copies of the Contract Documents are available online at <http://www.ci.woodburn.or.us/?q=blog-categories/bids-and-rfps> and at the Public Works Department - Engineering Division, located at:

City Hall Annex
190 Garfield Street
Woodburn, OR 97071.

- B. Questions regarding bidding, materials or technical requirements should be directed to the Project Manager at:

Pete Gauthier,
190 Garfield St.
Woodburn, OR 97071
Phone: 503.980.2429
Email: pete.gauthier@ci.woodburn.or.us

Or

Dago Garcia, PE, City Engineer
190 Garfield St.
Woodburn, OR 97071
Phone: 503.982.5248
Email: dago.garcia@ci.woodburn.or.us

- C. Bidder is responsible for completing and returning all page(s), attachment(s) which require a response.
- D. Plan Holder’s List – An electronic copy of the “Plan Holders List” is provided on the Agency website and will be periodically updated. Contractors, suppliers and others wishing to be added to this list should contact the Project Manager as identified in 2.B.
- E. Project Notifications – Addenda, clarifications, etc. shall be posted on the Agency website and are the responsibility of the Contractor to download before submission of bids. Contractor shall sign and submit with offer all Addenda associated (posted on website) with the project.

3. PROJECT FINANCING:

- A. This project is financed and paid for by the City of Woodburn.
- C. The Engineer's cost estimated range for the construction of this project is between \$150,000 and \$200,000.
- D. This project is subject to the prevailing wages rates under the Oregon Prevailing Wages Law (BOLD).
- E. This project is subject to prevailing wage rates available at:

www.oregon.gov/boli/WHD/PWR/Pages/pwr_state.aspx and listed as “Prevailing Wage Rates for Public Works Contracts in Oregon effective July 1, 2020” and “Prevailing Wage Rates Amendment Effective October 1, 2020.

4. CONSTRUCTION AGREEMENT

- A. The construction contract between Owner and Contractor shall be provided by The City of Woodburn. A sample Agreement is included in these documents.

5. PREBID CONFERENCE:

- A. Due to Covid restrictions no prebid conference is scheduled. Bidders are encouraged to visit the site on their own prior to bidding.

6. AWARD OF THE CONTRACT:

- A. Award of the Contract, by the Contract Review Board (City Council), will be by recommendation of the Public Works Department, based on the lowest cost offer of the responsive and responsible Bidder in accordance with Section 00130 of the Oregon Standard Construction Specifications and all modifications by Special Provisions.

7. SPECIAL CONCERNS:

- A. The section of sewer line from Harrison to church and the connection to 691 Harrison shall be priority.

8. TIME OF COMPLETION AND WORKING HOURS:

- A. All project work shall be completed within ninety (90) calendar days after the dated ‘Notice to proceed’.
- B. Working hours are Monday through Friday between 7:00am and 7:00pm.

**CITY OF WOODBURN
SIXTH ST. SANITARY SEWER REPLACEMENT**

**PART II
BID FORMS**

CERTIFICATION PAGE
FORM OF PROPOSAL
FIRST TIER SUBCONTRACTORS DISCLOSURE FORM
BID SUBMITTAL CHECKLIST

CERTIFICATION PAGE

Each Bidder (offeror) must read and comply with the following Sections. Failure to do so may result in bid/proposal (offer) rejection.

RESIDENCY INFORMATION

ORS 279A.120 (2) states "For the purposes of awarding a public contract, a contracting agency shall: (a) Give preference to goods or services that have been manufactured or produced in this state if price, fitness, availability and quality are otherwise equal; and (b) Add a percent increase to the bid of a nonresident bidder equal to the percent, if any, of the preference given to the bidder in the state in which the bidder resides."

"Resident bidder" means a bidder that has paid unemployment taxes or income taxes in this state during the 12 calendar months immediately preceding submission of the bid, has a business address in this state and has stated in the bid whether the bidder is a "resident bidder" [ORS 279A.120(1)(b)].

"Non-resident bidder" means a bidder who is not a "resident bidder" as defined above [ORS 279A.120 (1)(b)].

Check one: Bidder is a RESIDENT bidder NON-RESIDENT bidder.

CERTIFICATION OF COMPLIANCE WITH DISCRIMINATION LAWS

By my signature in Form of Proposal, I hereby attest or affirm under penalty of perjury that I am authorized to act on behalf of Contractor in this matter, and to the best of my knowledge the Contractor has not discriminated against minority, women or emerging small business enterprises certified under ORS 200.055, in obtaining any required subcontract or against a business enterprise that is owned or controlled by or that employs a disable veteran as defined in ORS 408.225.

CERTIFICATION OF COMPLIANCE WITH OREGON TAX LAWS

By my signature in Form of Proposal, I hereby attest or affirm under penalty of perjury that I am authorized to act on behalf of Contractor in this matter that I have authority and knowledge regarding the payment of taxes, and that Contractor is, to the best of my knowledge, not in violation of any Oregon Tax Laws.

For purposes of this certificate, 'Oregon Tax Laws' means those programs listed in ORS 305.380(4) which is incorporated herein by this reference. Examples include the state inheritance tax, personal income tax, withholding tax, corporation income and excise taxes, amusement device tax, timber taxes, cigarette tax, other tobacco tax, 9-1-1 emergency communications tax, the homeowners and renters property tax relief program and local taxes administered by the Department of Revenue.

VERIFICATION OF RESPONSIBILITY

The City reserves the right, pursuant to ORS 279C.375 and OAR 137-049-0390, to investigate and evaluate, at any time prior to award and execution of the contract, the lowest bidder's (apparent successful offeror's) ability to perform the contract. Submission of a signed offer shall constitute approval for the City to obtain any information the City deems necessary to conduct the evaluation. The City shall notify the apparent successful offeror, in writing, of any other documentation required. Being a responsible bidder may include having the appropriate financial, material, equipment, facility and personnel resources and expertise, or ability to obtain the resources and expertise to perform the contract. Contractor shall have a satisfactory record of contract performance. The Contractor shall also have a satisfactory record of integrity. An unsatisfactory record of integrity may include previous violations of state environmental laws or a false certifications made to any Public Agency. The Contractor is to be qualified legally to contract with the City of Woodburn. Failure to promptly provide any requested information may result in bid/proposal rejection.

The City may postpone the award of the contract after announcement of the apparent successful offeror in order to complete its investigation and evaluation. Failure of the apparent successful offeror to demonstrate responsibility, as required under ORS 279C.375 and OAR 137-049-0390, may render the offeror non-responsible and shall constitute grounds for offer rejection.

DRUG TESTING POLICY CERTIFICATION

DRUG-TESTING POLICY CERTIFICATION:

By my signature in Form of Proposal, I hereby attest or affirm under penalty of perjury that I am authorized to act on behalf of Contractor in the matter, and to the best of my knowledge the Contractor has a drug-testing program in place which applies to all employees. Contractor shall maintain a drug-testing program at all times during the performance of the Contract awarded. Failure to maintain such a program shall constitute a material breach of contract. [ORS 279C.505J

BID PROPOSAL

Honorable Mayor and City Council
City Hall
Woodburn, Oregon 97071

The undersigned, hereinafter called the Bidder, declares that the only persons or parties interested in this Proposal are those named herein, that the Proposal is in all respects fair and without fraud, which it is made without any connection or collusion with any person making another Proposal on this Contract.

The Bidder further declares that he has carefully examined the Contract Documents for the construction of the proposed improvements; that he has personally inspected the site; that he has satisfied himself as to the quantities of materials, items of equipment, and conditions or work involved, including the fact that the description of work and materials as included herein, is brief and is intended only to indicate the general nature of such items and to identify the said quantities with the detailed requirements of the Contract Documents; and that this Proposal is made according to the provisions and the terms of the Contract Documents, which Documents are herein attached and are hereby made a part of this Proposal.

The Bidder further agrees to complete construction of all work in all respects in accordance with the Special Provisions incorporated herein.

In the event the Bidder is awarded the Contract and shall fail to complete the work within the time limit set under Specifications of this document or extended time limit agreed upon, as more particularly set forth in the Contract Documents, liquidated damages shall be paid to the City of Woodburn, Oregon, using the rate formula outlined in the Special Provisions, and not less than \$150.00 per day, until the work shall have been finished, as provided by the Contract Documents.

The Bidder further proposes to accept as full payment for the work proposed herein the amount computed under the provisions of the Contract Documents and based on the following unit price amounts, it being expressly understood that the unit prices are independent of the exact quantities involved, that they represent a true measure of the labor and material required to perform the work, including all allowance for overhead and profit for each type and unit of work called for in these Contract Documents.

The amounts shall be shown in both words and figures. In case of discrepancy, the amount shown in words shall govern.

It is declared that the Bidder will comply with all the provisions of ORS 279C.800 through 279.870, Oregon Revised Statutes. The workmen on the project will be paid not less than the prevailing rates of wages.

It is agreed that if the Bidder is awarded the Contract for the work herein proposed and shall fail or refuse to execute the Contract and furnish the specified Performance Bond within ten (10) calendar days after receipt of notification of acceptance of his Proposal, then, in that event, the bid security in the sum of:

(In Words): _____

(In Numbers): \$ _____

deposited herewith according to the conditions of the Advertisement for Bids and Information to Bidders, shall be retained by the City of Woodburn, Oregon, as liquidated damages; and it is agreed that the said sum is a fair measure of the amount of damage the City of Woodburn will sustain in case the Bidder shall fail or refuse to enter into the contract for the said work and to furnish the Performance Bond as specified in the Contract Documents. Bid security in the form of a certified check shall be subject to the same requirements as a bid bond.

If the Bidder is awarded a construction contract on this proposal, the surety who will provide the Performance Bond will be:

_____ whose address is:

_____, _____, _____
Street City State Zip

Agents Name: _____ Phone No. _____

The address for all communications concerned with this Proposal and where the Contract shall be sent is:

Contractor: _____ doing business at:

_____, _____, _____
Street City State Zip

BID PROPOSAL

SIXTH ST. SANITARY SEWER REPLACEMENT

<u>Item No.</u>	<u>Description</u>	<u>QNTY.</u>	<u>UNITS</u>	<u>UNIT PRICE</u>	<u>TOTAL</u>
1	Mobilization and Cleanup	1	LS	\$	\$
2	Construct 48" MH	2	EA	\$	\$
3	Construct 6" SS main	365	\$/FT	\$	\$
4	Connect to Existing MH	2	EA	\$	\$
5	Connect to existing Laterals w/clean outs	5	EA	\$	\$
6	Abandon existing 6" sewer	220	\$/FT	\$	\$
7	Sawcut	1500	\$/FT	\$	\$
8	AC Patch	1300	\$/FT ²	\$	\$
9	Restore Concrete Driveway and curbs	1	LS	\$	\$
10	Restore Grass Areas	1	LS	\$	\$
		Total :		\$	\$

Bid Item #1 includes, but not limited to, all cost of bringing into and removing from the site, all materials, supplies, equipment, and manpower to complete the work and leaving the site in as good or better condition than before work was started.

Bid Item #2 includes all Labor and miscellaneous material, supplies, to Construct and connect the 48" SS MHs.

Bid Item #3 includes all Labor and miscellaneous material, supplies, to Construct the 6" SS line from the new MHs to the existing MHs at two locations a block apart.

Bid Item #4 includes materials and labor to connect the new 6" SS to the existing MH including coring and rechanneling.

Bid Item #5 includes all material and labor to connect existing service laterals to the new 6" sanitary sewer.

Bid Item #6 includes all equipment, material, and Labor to remove the existing clean outs and abandon the existing 6" SS in place.

Bid Item #7 includes all equipment, material, and Labor to sawcut the AC for the open trench in the street and any sawcutting necessary for driveway and curb restoration.

Bid Item #8 includes all equipment, material, and Labor necessary to restore the street.

Bid Item #9, includes all equipment, material, and Labor to restore the driveway at 935 6th Street.

Bid Item #10 includes all equipment, material, and Labor to restore all grass and planter areas disturbed by the work related to this contract.

The names of the principal officers of the corporation submitting this Proposal, or of the partnership, or of all persons interested in this Proposal as principals are as follows:

(If Sole Proprietor or Partnership)

In witness hereto the undersigned has set his (its) hand this _____ day of _____, 20____.

Signature of Bidder Title (If Corporation)

In witness whereof the undersigned corporation has caused this instrument to be executed and its seal affixed by its duly authorized officers this _____ day of _____, 20____.

Name of Corporation _____

By: _____

Title _____

Construction Contractor's Board No. _____

Attest: _____
Secretary

Initial "Bidder will comply with the provisions of (ORS) 279C.800 through 279C.870
(Oregon Revised Statutes)

In accordance with ORS 279A.120(b) and as specified in the Invitation to Bid, I hereby affirm that I [] am [] am not (check appropriate box) a "resident bidder". Resident Bidder means a bidder that has paid unemployment taxes or income taxes to the State of Oregon during the 12-month period preceding submission of this bid and has a business address in this state.

Attest: _____
Bidder

CITY OF WOODBURN, OR
FIRST-TIER SUBCONTRACTOR DISCLOSURE FORM

PROJECT NAME:	SIXTH ST, SANITARY SEWER REPLACEMENT		
PROJECT No:	2020-013-08	BID No:	2021-04
BID CLOSING DATE:	January 14, 2021	TIME:	2:00 PM
DISCLOSURE DEADLINE DATE:	January 14, 2021	TIME:	4:00 PM

This form must be submitted at the location specified in the Invitation to Bid on the advertised bid closing date with in two working hours after the advertised bid closing.

List below the name of each subcontractor that will be furnishing labor or materials and that is required to be disclosed, the category of work that the subcontractor will be performing and the dollar value of the subcontract. Enter "None" if there are no subcontractors that need to be disclosed. (IF NEEDED, ATTACH ADDITIONAL SHEETS.)

	<u>NAME</u>	<u>DOLLAR VALUE</u>	<u>CATEGORY OF WORK</u>
1		\$	
2		\$	
3		\$	
4		\$	
5		\$	

The above listed first-tier subcontractor(s) are providing labor and/or materials with a Dollar Value equal to or greater than:

- a. 5% of the total contract price or \$15,000 (including all alternates), whichever is greater; or
- b. \$350,000.00 regardless of the percentage of the total Contract Price.

FAILURE TO SUBMIT THIS FORM FILLED OUT BY THE DISCLOSURE DEADLINE WILL RESULT IN A NON-RESPONSIVE BID. A NON-RESPONSIVE BID WILL NOT BE CONSIDERED FOR AWARD.

Form Submitted by (Bidder Name): _____
Contact Name: _____ **Phone No:** _____
Deliver Form to Agency: _____ CITY OF WOODBURN
Person Designated to Receive Form: _____ CITY ENGINEER
Agency's Address: _____ 190 Garfield Street, Woodburn, OR 97071

**UNLESS OTHERWISE STATED IN THE ORIGINAL SOLICITATION,
THIS DOCUMENT SHALL NOT BE FAXED.**

BID SUBMITTAL CHECKLIST

The following is a checklist of the items that shall be submitted with the Bidder's bid Proposal

- Form of Proposal
- Bid Bond
- First Tier Subcontractor Disclosure Form (Submit within two hours after bid opening time)
- Certification Page
- Addendum(s)

**CITY OF WOODBURN
SIXTH ST. SANITARY SEWER REPLACEMENT**

PART III

CONTRACT FORMS

CERTIFICATE OF LIABILITY INSURANCE – (Sample)

CONSTRUCTION AGREEMENT – (Sample)

NOTICE OF AWARD – (Sample)

PREFORMANCE BOND FORM

PAYMENT BOND FORM

MAINTENANCE AND WARRANTY BOND FORM

NOTICE TO PROCEED – (Sample)

ACORD™ CERTIFICATE OF LIABILITY INSURANCE DATE (MM/DD/YYYY)

PRODUCER FAX	THIS CERTIFICATE IS ISSUED AS A MATTER OF INFORMATION ONLY AND CONFERS NO RIGHTS UPON THE CERTIFICATE HOLDER. THIS CERTIFICATE DOES NOT AMEND, EXTEND OR ALTER THE COVERAGE AFFORDED BY THE POLICIES BELOW.	
INSURED	INSURERS AFFORDING COVERAGE INSURER A: INSURER B: INSURER C: INSURER D: INSURER E:	NAIC #

COVERAGES
 THE POLICIES OF INSURANCE LISTED BELOW HAVE BEEN ISSUED TO THE INSURED NAMED ABOVE FOR THE POLICY PERIOD INDICATED. NOTWITHSTANDING ANY REQUIREMENT, TERM OR CONDITION OF ANY CONTRACT OR OTHER DOCUMENT WITH RESPECT TO WHICH THIS CERTIFICATE MAY BE ISSUED OR MAY PERTAIN, THE INSURANCE AFFORDED BY THE POLICIES DESCRIBED HEREIN IS SUBJECT TO ALL THE TERMS, EXCLUSIONS AND CONDITIONS OF SUCH POLICIES. AGGREGATE LIMITS SHOWN MAY HAVE BEEN REDUCED BY PAID CLAIMS.

INSR	ADD'L LTR	TYPE OF INSURANCE	POLICY NUMBER	POLICY EFFECTIVE DATE (MM/DD/YY)	POLICY EXPIRATION DATE (MM/DD/YY)	LIMITS
		GENERAL LIABILITY <input type="checkbox"/> COMMERCIAL GENERAL LIABILITY <input type="checkbox"/> CLAIMS MADE <input type="checkbox"/> OCCUR Owners and Cont Prot GEN'L AGGREGATE LIMIT APPLIES PER: <input type="checkbox"/> POLICY <input type="checkbox"/> PRO-JECT <input type="checkbox"/> LOC				EACH OCCURRENCE \$ DAMAGE TO RENTED PREMISES (Ea occurrence) \$ MED EXP (Any one person) \$ PERSONAL & ADV INJURY \$ GENERAL AGGREGATE \$ PRODUCTS - COMP/OP AGG \$ Fire Damage (any one fire)
		AUTOMOBILE LIABILITY <input type="checkbox"/> ANY AUTO <input type="checkbox"/> ALL OWNED AUTOS <input type="checkbox"/> SCHEDULED AUTOS <input type="checkbox"/> HIRED AUTOS <input type="checkbox"/> NON-OWNED AUTOS				COMBINED SINGLE LIMIT (Ea accident) \$ BODILY INJURY (Per person) \$ BODILY INJURY (Per accident) \$ PROPERTY DAMAGE (Per accident) \$
		GARAGE LIABILITY <input type="checkbox"/> ANY AUTO				AUTO ONLY - EA ACCIDENT \$ OTHER THAN AUTO ONLY: EA ACC \$ AGG \$
		EXCESS/UMBRELLA LIABILITY <input type="checkbox"/> OCCUR <input type="checkbox"/> CLAIMS MADE DEDUCTIBLE RETENTION \$				EACH OCCURRENCE \$ AGGREGATE \$ \$ \$
		WORKERS COMPENSATION AND EMPLOYERS' LIABILITY ANY PROPRIETOR/PARTNER/EXECUTIVE OFFICER/MEMBER EXCLUDED? If yes, describe under SPECIAL PROVISIONS below				WC STATU-TORY LIMITS OTH-ER E.L. EACH ACCIDENT \$ E.L. DISEASE - EA EMPLOYEE \$ E.L. DISEASE - POLICY LIMIT \$
		OTHER				

DESCRIPTION OF OPERATIONS / LOCATIONS / VEHICLES / EXCLUSIONS ADDED BY ENDORSEMENT / SPECIAL PROVISIONS

The City of Woodburn, OR its elected and appointed officials, officers, agents, employees and volunteers.

CERTIFICATE HOLDER City of Woodburn Public Works Dept. 190 Garfield St. Woodburn, OR 97071	CANCELLATION SHOULD ANY OF THE ABOVE DESCRIBED POLICIES BE CANCELLED BEFORE THE EXPIRATION DATE THEREOF, THE ISSUING INSURER WILL ENDEAVOR TO MAIL <u>30</u> DAYS WRITTEN NOTICE TO THE CERTIFICATE HOLDER NAMED TO THE LEFT, BUT FAILURE TO MAIL SUCH NOTICE SHALL IMPOSE NO OBLIGATION OR LIABILITY OF ANY KIND UPON THE INSURER, ITS AGENTS OR REPRESENTATIVES. AUTHORIZED REPRESENTATIVE
--	---

CONSTRUCTION AGREEMENT

THIS AGREEMENT, made this ____ day of _____, 20____, by and between _____, hereinafter called "CONTRACTOR" and the CITY OF WOODBURN, an Oregon Municipal Corporation, hereinafter called "City" or "Owner".

The Contractor, for the consideration hereinafter named, does hereby agree to furnish all materials, equipment, labor and necessary implements for the construction of and doing such other work as is necessary to make an appropriate and complete improvement.

All of said work shall be done according to the terms, conditions, and requirements of the Contract Documents including the: Advertisement of Bids, Contractor's signed Proposal, information to bidders, special specifications, general conditions, standard specifications, general specifications, and plans and Addendum Nos. _____ for said improvement, which Contract Documents by this reference are made a part of this agreement.

Said improvement shall be completed by the date specified in said Contract Documents and if not so completed, unless said time for completion is extended, as provided in the Contract Documents, or if extended, if the same is not completed within time extended, the City will suffer liquidated damages as specified in the Contract Documents, which liquidated damages shall be retained out of any monies due or to become due under this agreement.

Payments shall be made as provided in the Contract Documents. The contract amount, as approved by the Council on _____, 20____, and agreed by the Contractor, is \$_____.

The City will pay the required fee to the Bureau of Labor and Industries equal to one-tenth of one percent (0.1 percent) of the price of this contract, minimum fee in the amount of \$250.00 and maximum fee of \$7,500.00.

The Contractor will pay the prevailing wage rates in accordance with ORS279C.830 and as amended by Davis Bacon and all current amendments as set forth in the Contract.

NOW, THEREFORE, in consideration of the faithful performance of the covenants and agreements hereinbefore made by the Contractor, the City hereby covenants and agrees to pay the Contractor as in said Contract Documents provided.

IN WITNESS WHEREOF, the respective parties hereto have each caused these presents to be executed in duplicate the day and year first above written.

CITY OF WOODBURN, OREGON

ATTESTED: _____
HEATHER PIERSON, *CITY RECORDER* Eric Swenson, *MAYOR*

CONTRACTOR: _____
Organization

By: _____ Title: _____

NOTICE OF CONTRACT AWARD

PROJECT DESCRIPTION: **SIXTH ST. SANITARY SEWER REPLACEMENT**

FILE No: **2020-013-08**

BID No: **2021-04**

The Owner has considered the bid submitted by you on **JANUARY 14, 2021** for the above described work in response to its Invitation to Bid.

You are hereby notified that on **FEBRUARY 8, 2021** the City Council accepted your bid for construction of the work in the amount of **\$XXX,XXX.00**

You are required under the terms of the Notice Inviting Bids and the Information for Bidders to execute the Agreement and furnish bonds and certificates of insurance within **14-calendar days** from the date of this Notice to you.

If you fail to execute said Agreement and furnish said bonds and certificates of insurance within 14-days of this Notice, said Owner will be entitled to consider all your rights arising out of the Owner's acceptance of your bid to be abandoned and as a forfeiture of your Bid Bond. The Owner will be entitled to such other rights as may be granted by law.

You are required to return an acknowledged copy of this Notice of Award to the Owner.

Dated this **9** of **February, 2021**

By _____ Title _____

Contractor shall fill in all information below this line and return original signed copy

ACCEPTANCE OF NOTICE

Receipt of the foregoing Notice of Award is hereby acknowledged

By: _____

Title: _____

This: _____ day of _____ 2021.

Bond No. _____
Solicitation _____
Project BID#: **2021-04**

PERFORMANCE BOND

KNOW ALL MEN BY THESE PRESENTS that, _____,
as the Principal, and _____, a corporation organized and
existing under the laws of the State of Oregon, and duly authorized to transact a surety
business in the State of Oregon, as Surety, are held and firmly bound unto the City of
Woodburn, a municipal corporation of the State of Oregon, in the penal sum of
\$_____ Dollars \$_____, lawful money of the United States of
America, for the payment whereof well and truly to be made, we and each of us, jointly
and severally, bind ourselves, our and each of our heirs, executors, administrators
successors and assign, firmly by these presents.

WHEREAS, the Principal has entered into a contract with the City of Woodburn,
the plans, specifications, terms and conditions of which are contained in the above-
referenced Solicitation;

WHEREAS, the terms and conditions of the contract, together with applicable
plans, standard specifications, special provisions, schedule of performance, and
schedule of contract prices, are made a part of this Performance Bond by reference,
whether or not attached to the contract (all hereafter called the "Contract"); and

WHEREAS, the Principal has agreed to perform the Contract in accordance with
the terms, conditions, requirements, plans and specifications, and all authorized
modifications of the Contract which increase the amount of the work, the amount of the
Contract, or constitute an authorized extension of the time for performance, notice of
any such modifications hereby being waived by the Surety,

NOW, THEREFORE, THE CONDITION OF THIS BOND IS SUCH:

That if the Principal herein shall faithfully and truly observe and comply with the
terms, conditions and provisions of the Contract, in all respects, and shall well and truly
and fully do and perform all matters and things undertaken by Contractor to be
performed under the Contract, upon the terms set forth therein, and within the time
prescribed therein, or as extended as provided in the Contract, with or without notice to
the Sureties, and shall indemnify and save harmless the City of Woodburn, the, its
officers, employees and agents, against any direct or indirect damages or claim of every
kind and description that shall be suffered or claimed to be suffered in connection with
or arising out of the performance of the Contract by the Principal or its subcontractors,
and shall in all respects perform said contract according to law, then this obligation is to
be void; otherwise, it shall remain in full force and effect.

Nonpayment of the bond premium will not invalidate this bond nor shall the City
of Woodburn, be obligated for the payment of any premiums.

This bond is given and received under authority of ORS Chapter 279C, the provisions of which hereby are incorporated into this bond and made a part hereof.

Contractor

BY:

TITLE: _____

Surety

By: _____
Attorney-In-Fact

Bond No. _____
Solicitation: _____
Project Bid#: **2021-04**

PAYMENT BOND

KNOW ALL MEN BY THESE PRESENTS that, _____,
as the Principal, and _____, a corporation organized and
existing under the laws of the State of Oregon, and duly authorized to transact a surety
business in the State of Oregon, as Surety, are held and firmly bound unto the City of
Woodburn, a municipal corporation of the State of Oregon, in the penal sum of
\$_____ Dollars \$_____, lawful money of the United States of
America, for the payment whereof well and truly to be made, we and each of us, jointly
and severally, bind ourselves, our and each of our heirs, executors, administrators
successors and assign, firmly by these presents.

WHEREAS, the Principal has entered into a contract with the City of Woodburn,
the plans, specifications, terms and conditions of which are contained in the above-
referenced Solicitation;

WHEREAS, the terms and conditions of the contract, together with applicable
plans, standard specifications, special provisions, schedule of performance, and
schedule of contract prices, are made a part of this Payment Bond by reference,
whether or not attached to the contract (all hereafter called the "Contract"); and

WHEREAS, the Principal has agreed to perform the Contract in accordance with
the terms, conditions, requirements, plans and specifications, and all authorized
modifications of the Contract which increase the amount of the work, the amount of the
Contract, or constitute an authorized extension of the time for performance, notice of
any such modifications hereby being waived by the Surety,

NOW, THEREFORE, THE CONDITION OF THIS BOND IS SUCH:

That if the Principal shall faithfully and truly observe and comply with the terms,
conditions and provisions of the Contract, in all respects, and shall well and truly and
fully do and perform all matters and things by it undertaken to be performed under said
Contract and any duly authorized modifications that are made, upon the terms set forth
therein, and within the time prescribed therein, or as extended therein as provided in the
Contract, with or without notice to the sureties, including the conditions listed in ORS
279.310 to 279.320, and shall indemnify and save harmless the City of Woodburn, its
officers, employees and agents, against any claim for direct or indirect damages of
every kind and description that shall be suffered or claimed to be suffered in connection
with or arising out of the performance of the Contract by the Contractor or its
Subcontractors, and shall promptly pay all persons supplying labor, materials or both to
the Principal or its Subcontractors for prosecution of the work provided in the Contract;
and shall promptly pay all contributions due the State Industrial Accident Fund and the
State Unemployment Compensation Fund from the Principal or its Subcontractor in
connection with the performance of the Contract; and shall pay over to the Oregon

Department of Revenue all sums required to be deducted and retained from the wages of employees of the Principal and its Subcontractors pursuant to ORS 316.167, and shall permit no lien nor claim to be filed or prosecuted against the City of Woodburn on account of any labor or materials furnished; and shall do all things required of the Principal by the laws of this State, then this obligation shall be void; otherwise, it shall remain in full force and effect.

Nonpayment of the bond premium will not invalidate this bond nor shall the City of Woodburn, be obligated for the payment of any premiums.

This bond is given and received under authority of ORS Chapter 279C, the provisions of which hereby are incorporated into this bond and made a part hereof.

Contractor

BY:

TITLE: _____

Surety

By: _____

Attorney-In-Fact

Bond No. _____
Solicitation _____
Project Bid#: **2021-04**

MAINTENANCE/WARRANTY BOND

KNOW ALL MEN BY THESE PRESENTS that, _____,
as the Principal, and _____, a corporation organized and
existing under the laws of the State of Oregon, and duly authorized to transact a surety
business in the State of Oregon, as Surety, are held and firmly bound unto the City of
Woodburn, a municipal corporation of the State of Oregon, in the penal sum of
\$_____ Dollars \$_____, lawful money of the United States
of America, for the payment whereof well and truly to be made, we and each of us, jointly
and severally, bind ourselves, our and each of our heirs, executors, administrators
successors and assign, firmly by these presents.

WHEREAS, the Principal has entered into a contract with the City of Woodburn, the
plans, specifications, terms and conditions of which are contained in the above-referenced
Solicitation;

WHEREAS, the terms and conditions of the contract, together with applicable plans,
standard specifications, special provisions, schedule of performance, and schedule of
contract prices, are made a part of this Maintenance/Warranty Bond by reference, whether
or not attached to the contract (all hereafter called the "Contract"); and

WHEREAS, the Principal has agreed to perform the Contract in accordance with the
terms, conditions, requirements, plans and specifications, and all authorized modifications
of the Contract which increase the amount of the work, the amount of the Contract, or
constitute an authorized extension of the time for performance, notice of any such
modifications hereby being waived by the Surety,

NOW, THEREFORE, THE CONDITION OF THIS BOND IS SUCH:

That the Principal agrees to warrant to the City of Woodburn that the construction is,
and will remain for a period of one (1) year from the date of acceptance, free from defects
in materials and workmanship.

That if the Principal herein shall faithfully and truly observe the terms, provisions,
conditions, stipulations, directions, and requirements of the Contract and shall in all
respects, whether the same be enumerated herein or not, faithfully comply with the same
and shall assume the defense of indemnify and save harmless the City of Woodburn, its
officers, agents, and employees from all claims, liabilities, loss, damage or injury which
may have been suffered or claimed to have been suffered to persons or property directly or
indirectly resulting from or arising out of the operations or conduct of the Principal or any
subcontractor in the performance of the work under the Contract and shall indemnify and
make whole the City for any injury or damage to any street, highway, avenue, or road or
any part thereof, resulting from the operations or conduct of the Principal or any
subcontractor in connection with performance or conduct of the work under the Contract,

and shall in all respects faithfully keep and observe all of said terms, provision, conditions, stipulations, directions, and requirements, then this obligation is void, otherwise, it shall remain in full force and effect.

WITNESS our hand and seals this _____ day of _____, 2020.

Contractor

BY:

TITLE: _____

Surety

By: _____

Attorney-In-Fact

NOTICE TO PROCEED

**PUBLIC WORKS DEPT.
ENGINEERING DIV.**



PROJECT NAME:	SIXTH ST. SANITARY SEWER REPLACEMENT		
BID #:	2021-04	PROJECT No #:	2020-013-08
AMOUNT:	\$	BEGIN DATE:	
CONTRACTOR:		CCB #:	
ADDRESS:			

You are hereby notified to commence work on the referenced contract, and shall fully complete all of the work of said contract within 90 calendar days.

The completion date is therefore: **MAY 31, 2021**

The contract provides for the assessment of liquidated damages for each consecutive calendar day after the above-established contract completion date that the work remains incomplete in the amount of: \$ _____ per day.

PM for THE CITY OF WOODBURN: Pete Gauthier

DATE: _____

Contractor: *Complete items below this line and return Document to Owner within seven (7) days:*

CONTRACTOR'S ACCEPTANCE OF THIS NOTICE

Receipt of the foregoing Notice to Proceed is hereby acknowledged:

SIGNED: _____

TITLE: _____

DATE: _____

**CITY OF WOODBURN
SIXTH ST. SANITARY SEWER REPLACEMENT**

PART IV

SPECIFICATIONS

GENERAL CONDITIONS

SPECIAL PROVISIONS

PART 00100 – GENERAL CONDITIONS

**SECTION 00110 - ORGANIZATION, CONVENTIONS,
ABBREVIATIONS AND DEFINITIONS**

Comply with Section 00110 of the Standard Specifications modified as follows:

00110.05(a) Grammar - Add the following bullet to the bullet list:

- For the purposes of this Contract, the terms "sidewalk ramp" and "sidewalk ramps" shall respectively refer to and shall be read to mean "curb ramp" and "curb ramps".

00110.05(e) Reference to Websites - Add the following bullet list to the end of this subsection:

- City of Woodburn Public Works Department:
https://www.woodburn-or.gov/?q=public_works
- City of Woodburn Public Works Department Bids and RFPs:
<http://www.ci.woodburn.or.us/?q=blog-categories/bids-and-rfps>
- American Traffic Safety Services Association (ATSSA)
www.atssa.com
- ODOT Construction Section
www.oregon.gov/odot/construction/pages/index.aspx
- ODOT Construction Section - Qualified Products List (QPL)
www.oregon.gov/ODOT/Construction/Pages/Qualified-Products.aspx
- ODOT Estimating
www.oregon.gov/ODOT/Business/Pages/Steel.aspx
- Oregon Legislative Counsel
www.oregonlegislature.gov/lc
- ODOT Procurement Office - Conflict of Interest Guidelines and Disclosure Forms
www.oregon.gov/ODOT/Business/Procurement/Pages/PSK.aspx
- ODOT Procurement Office - Construction Contracts Unit Notice of Intent
www.oregon.gov/ODOT/Business/Procurement/Pages/NOI.aspx
- ODOT Procurement Office - Construction Contracts Unit prequalification forms
www.oregon.gov/odot/business/procurement/pages/bid_award.aspx
- Oregon Secretary of State: State Archives
sos.oregon.gov/archives/Pages/default.aspx

- ODOT Traffic Control Plans Unit
www.oregon.gov/ODOT/Engineering/Pages/Work-Zone.aspx
- ODOT Traffic Standards
www.oregon.gov/ODOT/Engineering/Pages/Signals.aspx

00110.20 Definitions – Delete the “3D Engineering Model” and “3D Construction Model” definitions.

Replace the “Agency” definition with the following definition:

Agency – The City of Woodburn Public Works Department – Engineering Division.

Add the following definition:

Agency Website – This is the website of the Public Works Department, Engineering Division as owned, controlled and administrated by the City of Woodburn, OR. The URL being referenced when this term is used shall be the following:

<http://www.ci.woodburn.or.us/?q=blog-categories/bids-and-rfps>

Replace the "Bid Booklet" definition with the following definition:

Bid Booklet - The version that can be accessed and printed from the Agency website.

Replace the “Traveled Way” definition with the following definition:

Traveled Way - That part of the Highway for moving vehicles, exclusive of berms and Shoulders.

SECTION 00120 - BIDDING REQUIREMENTS AND PROCEDURES

Comply with Section 00120 of the Standard Specifications modified as follows:

00120.00 Prequalification of Bidders - Replace this subsection, except for the subsection number and title, with the following:

The Agency will prequalify Bidders according to ODOT's Oregon Administrative Rules and prequalification procedures. A Bidder must file for prequalification and **NO** fee. Prequalification must be renewed annually. Bidders shall make application for prequalification and for required renewals on standard forms available from the ODOT Procurement Office - Construction Contracts Unit website. Bidders shall return the completed application to the Dago Garcia at 190 Garfield St. Woodburn, OR 97071 or e-mail to dago.garcia@ci.woodburn.or.us. No facsimile of Prequalification will be accepted.

Contracts will only be awarded to Bidders who, at the time of Bid Opening, are prequalified in the Class or Classes of Work specified in the Special Provisions, except that a Bidder whose prequalification has been revoked or revised as provided in ORS 279C.430(4) may also be eligible for Award under that statute if the Project was advertised prior to the revocation or revision. The Agency will consider a Bid from a Bidder whose complete application for prequalification has been received by the Public Works Department – Engineering Division Office at least 3 Calendar Days before the opening of Bids. Bidders shall submit Bids in the same company name used on the prequalification application; provided however, if Bidder's legal name has changed since the submittal of its application for prequalification, it shall submit its Bid under its current legal name with the former name referenced by "formerly known as".

The Agency will regularly evaluate the performance of Contractors on its projects for purposes of responding to reference checks, future prequalification and determinations of responsibility.

00120.01 General Bidding Requirements - In the paragraph that begins "Bidders may submit ...", replace the paragraph with the following sentence:

Bidders may submit Bids by paper only. No electronic (e-mail or facsimile) Bids will be accepted.

00120.05 Request for Plans, Special Provisions, and Bid Booklets - Replace this subsection, with the following subsection:

00120.05 Request for Plans, Special Provisions, and Bid Booklets:

(a) Informational Plans and Special Provisions - Informational Project Plans and Special Provisions are available, free of charge, on the Agency's website.

(b) Bidding Plans, Special Provisions, and Bid Booklets - Bidders must submit paper Bids.

(1) Paper Bids - Bidders submitting bids shall access and print Plans, Special Provisions, and Bid Booklets from the Agency's website. Bidders obtaining Plans, Special Provisions, and Bid Booklets must register on Agency's list of "Holders of Bidding Plans". Bids will be considered responsive only if Bidders are registered as "Holders of Bidding Plans".

Delete the paragraph that begins with the following;

“(2) Electronic Bids - Bidders ...”

The Plans, which are applicable to the Work to be performed under the Contract, are included in these Special Provisions.

00120.10 Bid Booklet - In the paragraph that begins "The Bid Section includes all pages after...", add the following bullet to the bullet list:

- Certificate of nondiscrimination regarding ORS 279A.110 and certificate regarding policy and practice against sexual harassment, sexual assault and discrimination against employees who are members of a protected class as required by Chapter 212, Oregon Laws 2017 (House Bill 3060)

00120.30 Changes to Plans, Specifications, or Quantities before Opening of Bids - Replace all “ODOT eBids website” wording in this section with “Agency’s website”.

Delete “(see 00110.05(e))” wording in this section.

00120.40(a-1) Paper Bids - Replace this subsection, except for the subsection number and title, with the following:

Bidders shall not alter, in any manner, the (paper) documents within the Bid Section that are accessed and printed from the Agency’s website. Bidders shall complete the certifications and statements included in the Bid Section of the Bid Booklet according to the instructions. Signature of the Bidder’s authorized representative thereon constitutes the Bidder's confirmation of an agreement to all certifications and statements contained in the Bid Booklet. Entries on paper documents in the Bid Section shall be in ink or typed.

The Bidder shall properly complete and bind all the paper documents in the Bid Section, as specified in 00120.10, together with all other required documents that are part of the Bid Booklet, between the front and back covers of the Bid Booklet, except that the Bid Bond is not required if another permissible type of Bid guaranty is provided. (see 00120.40(e))

00120.40(a-2) Electronic Bids – Delete this subsection in its entirety.

00120.40(c-2) Electronic Bid Schedule Entries – Delete this subsection in its entirety.

00120.40(e-2) Bid Guaranty with Electronic Bids - Delete this subsection in its entirety.

00120.40(f) Disclosure of First-Tier Subcontractors - Replace this subsection, except for the subsection number and title, with the following:

Without regard to the amount of a Bidder’s Bid, if the Agency’s cost range for a public improvement Project in the “Invitation to Bid”, or in other advertisement or solicitation documents, exceeds \$100,000, the Bidder shall, within 2 working hours of the time Bids are due to be submitted, submit to the Agency, on a form provided by the Agency, a disclosure

SIXTH ST. SANITARY SEWER REPLACEMENT

identifying any first-tier Subcontractors that will furnish labor or labor and Materials, and whose contract value is equal to or greater than:

- 5% of the total Project Bid, but at least \$15,000; or
- \$350,000, regardless of the percentage of the total Project Bid.

For each Subcontractor listed, Bidders shall state:

- The name of the Subcontractor;
- The dollar amount of the subcontract; and
- The category of Work that the Subcontractor would be performing.

If no subcontracts subject to the above disclosure requirements are anticipated, a Bidder shall so indicate by entering "NONE" or by filling in the appropriate check box. For each Subcontractor listed, Bidders shall provide all requested information. An incomplete form will be cause for rejection of the Bid.

The Subcontractor Disclosure Form may be submitted for a paper Bid (See 00120.05(b-1) either:

By filling out the Subcontractor Disclosure Form printed from the Bid Booklet on the Agency's Engineering Division's website.

Subcontractor Disclosure Forms will be considered late if not received by the Agency within 2 working hours of the time designated for receiving Bids.

The Agency is not responsible for partial, failed, illegible or partially legible facsimile (FAX) transmissions or submittals, and such forms may be rejected as incomplete.

In the event that multiple Subcontractor Disclosure Forms are submitted, the last version received prior to the deadline will be considered to be the intended version.

Bids not in compliance with the requirements of this Subsection will be considered non-responsive.

00120.45 Submittal of Bids – Replace subsections (a) with the following:

00120.45 Submittal of Bids – Bids may be submitted by mail, parcel delivery service, or hand delivery to the office and address and at the time given in the Bid Booklet. Submit Bids in a sealed envelope and marked on the outside of the envelope as required by the Invitation to Bid. Closing time for acceptance of Bids is 2:00:00 p.m. local time on the day of Bid Opening. Bids submitted after the time set for receiving Bids will not be opened or considered. The Agency assumes no responsibility for the receipt and return of late Bids.

00120.45(b) Electronic Bids - Delete this subsection in its entirety.

00120.60(a) Paper Bids - In the paragraph that begins "Information entered into...", replace the words " ODOT Procurement Office" with the words "Agency".

In the paragraph that begins "A Bidder may withdraw...", replace the words "ODOT Procurement Office " with the words "Agency".

00120.60(b) Electronic Bids – Delete this subsection in its entirety.

00120.70 Rejection of Nonresponsive Bids - Add the following bullets to the end of the bullet list:

- The Bidder has liquidated and delinquent debt owed to the State or any department or agency of the State.

SECTION 00130 - AWARD AND EXECUTION OF CONTRACT

Comply with Section 00130 of the Standard Specifications modified as follows:

00130.10 Award of Contract - Replace the paragraph that begins "The Agency will provide Notice of Intent to Award..." with the following bullet:

The Agency will provide Notice of Intent to Award on the Agency's website.

00130.15 Right to Protest Award - Replace this subsection number and title and replace the sentence that begins "Before the Agency will..." with the following number and title and sentence:

00130.15 Right to Protest Award - Adversely affected or aggrieved Bidders, limited to the here apparent lowest Bidders and any other Bidder directly in for Contract Award, may submit to the Agency a written protest of the Agency's intent to Award within 3 working days following posting of the Notice of Intent to Award on the Agency's website. The protest shall specify the grounds upon which it is based.

The Agency is not obligated to consider late protests.

00130.50(a) By the Bidder - In the paragraph that begins "The successful Bidder...", replace the words "ODOT Procurement Office – Construction Contract Unit" with the words "Agency's Project Manager".

SECTION 00140 - SCOPE OF WORK

Comply with Section 00140 of the Standard Specifications.

SECTION 00150 - CONTROL OF WORK

Comply with Section 00150 of the Standard Specifications modified as follows:

00150.15 Construction Stakes, Lines, and Grades: - Replace this subsection number and title with the following number and title subsection:

00150.15 Construction Stakes, Lines, and Grades: All new construction is relative to existing fixed pipes and structures. The Engineer will assist in defining the location of the reference points, but the Contractor shall be responsible for final location and fit of all equipment. Survey work, if any, will be considered incidental to the Contract.

00150.30 Delivery of Notices - Add the following to the end of this subsection:

For purposes of this subsection, the time zone is Pacific Standard Time (PST) to determine time of receipt of notices and other documents. For purposes of this subsection, non-business days are Saturdays, Sundays and legal holidays as defined by ORS 187.010 and 187.020.

Following Notice to Proceed, all notices and other documents submitted to the Contractor by the Engineer, or to the Engineer by the Contractor, electronically under 00170.08:

- If recorded in Doc Express® as received before 5:00 p.m. PST on a business day it shall be considered as received on the business day on which it was actually received in Doc Express®.
- If recorded in Doc Express® as received on a non-business day, or after 5:00 p.m. PST on a business day, it shall be considered as received at 8:00 a.m. PST on the next business day.

Claims must be submitted on paper documents according to Section 00199.

00150.35 Plans, 3D Engineering Models, Working Drawings, and 3D Construction Models: Remove all of the following words from this subsection "3D Engineering Models, 3D Construction Models.

00150.50(c) Contractor Responsibilities - Add the following subsection:

00150.50(f) Utility Information:

Contact those Utilities having buried facilities and request that they locate and mark them for their protection prior to construction.

<u>UTILITY</u>	<u>CONTACT PERSON</u>	<u>PHONE NUMBER</u>
Century Link	Josh Fallin	503.399.4931
AT&T	Tom Normoyle	503.588.1899
NWN Gas	Daniel Kizer	503.226.4211ext8166
PGE	Darrin Perkins	503.463.4325
DataVision	Dennis Weddle	503-949-9701
Wave Cable/Internet	Derek Anderson	503.798-6651
City Water	Byron Brooks	503.980.5235
City Sewer Collections and Streets	Craig Prosser	503.982.5481

<u>UTILITY</u>	<u>CONTACT PERSON</u>	<u>PHONE NUMBER</u>
Republic Services - Solid Waste	Dispatch	503.981.1278
US Postal Service	Kevin McGrory	503.982.0186
First Student - School Bus	Delores Stubblefield	503.982.1427
911 - Non Emergency	Operator/Dispatch	503.982.2340

This Project is located within the Oregon Utility Notification Center area which is a Utilities notification system for notifying owners of Utilities about Work being performed in the vicinity of their facilities. The Utilities notification system telephone number is 811 (or use the old number which is 1-800-332-2344).

Further notify and coordinate with the following:

SECTION 00170 - LEGAL RELATIONS AND RESPONSIBILITIES

Comply with Section 00170 of the Standard Specifications modified as follows:
Add the following subsection:

00170.04 Patents, Copyrights, and Trademarks - Replace the paragraph that begins " Prior to use of designs, devices, materials, or processes..." with the following paragraph:

Prior to use of designs, devices, materials, or processes protected by patent, copyright, or trademark, the Contractor shall obtain from the Entity entitled to enforce the patent, copyright, or trademark all necessary evidence of Contractor's legal right to use such design, device, material, or process.

00170.05 Assignment of Antitrust Rights - Replace the bullet that reads "ORS 646.725; and" with the following bullet:

- ORS 646.725; or

SIXTH ST. SANITARY SEWER REPLACEMENT

00170.07 Record Requirements - In the paragraph that begins "For purposes of this Subsection, the term...", replace the words "OAR 731-005-0780" with the words "OAR 734-010-0400".

00170.07(a) Records Required - In the paragraph that begins "These records shall include...", replace the bullet that begins "Contracts or documents of other...", with the following bullet:

- Contracts or documents of other arrangements with any Related Entity as defined in OAR 734-010-0400.

In the paragraph that begins "The Contractor shall include...", replace the words "OAR 731-005-0780" with the words "OAR 734-010-0400".

00170.07(b) Access to Records - In the paragraph that begins "The Contractor shall provide...", replace the words "OAR 731-005-0780(9)" with the words "OAR 734-010-0400(9)".

00170.62 Labor Nondiscrimination - Add the following sentence to the end of this subsection:

It is a material term of this Contract that the Contractor certifies by entering into this Contract that the Contractor has a written policy and practice that meets the requirements described in Chapter 212, Oregon Laws 2017 (House Bill 3060) for preventing sexual harassment, sexual assault and discrimination against employees who are members of a protected class and that the Contractor shall maintain the policy and practice in force during the entire term of this Contract.

00170.60 Safety, Health and Sanitation Provisions – Add the following paragraph to the end of this subsection:

The Contractor is responsible to require each subcontractor at every tier to comply with the requirements of OAR 437-002-0146, Oregon OSHA’s Confined Space Rule including a copy of all closed permit entry forms to the Agency Project Manager within 24 hours of closing the permit.

00170.70(a) Insurance Coverages - The following insurance coverages and dollar amounts are required pursuant to this subsection:

Insurance Combined Single Limit Annual Aggregate

Coverages	per Occurrence	Limit
Commercial General Liability	\$1,000,000.00	\$2,000,000.00
Commercial Automobile Liability	\$1,000,000.00	(aggregate limit not required)

00170.70(c) Additional Insured - Add the following paragraph and bullet to the end of this subsection:

Add the following as Additional Insureds under the Contract:

SIXTH ST. SANITARY SEWER REPLACEMENT

- The City of _Woodburn, OR and its officers, agents, representatives, volunteers and employees

00170.72 Indemnity/Hold Harmless - Add the following paragraph and bullets to the end of this subsection:

Extend indemnity, defense and hold harmless to the Agency and the following:

- The City of _Woodburn, OR and its officers, agents, representatives, volunteers and employees

SECTION 00180 - PROSECUTION AND PROGRESS

Comply with Section 00180 of the Standard Specifications modified as follows:

00180.40(a) In General – Add the following bullets to this subsection:

- Street Closures are not allowed in this project.
- Provided and maintain access to all homes, School and Business at all times.
- All work shall be accomplished between 7:00 AM and 7:00 PM every day from Monday through Friday, excluding Legal Holidays.

Add the following subsection:

00180.40(c) Specific Limitations - Limitations of operations specified in these Special Provisions include, but are not limited to, the following:

Limitations	Subsection
Cooperation with Utilities	00150.50
Cooperation with Other Contractors	00150.55
On-Site Work	00180.40(b)
Contract Time	00180.50(h)
Special Events	00220.40(e)(2)(b)
Regulated Work Areas	00290.34(a)
Noise Control	00290.32

00180.41 Project Work Schedules - After the paragraph that begins "One of the following Type..." add the following paragraph:

In addition to the "look ahead" Project Work schedule, a Type _____ schedule as detailed in the Standard Specifications is required on this Contract.

00180.42 Preconstruction Conference - Add the following paragraph to the end of this subsection:

The Contractor shall conduct a group Utilities scheduling meeting with representatives from the Utility companies involved with this Project and the Engineer before the preconstruction conference. The Contractor shall incorporate the Utilities time needs into the Contractor's schedule submitted at the preconstruction conference.

00180.50(c) Beginning of Contract Time - Replace this subsection, except for the subsection number and title, with the following:

When the Contract Time is stated in Calendar Days, counting of Contract Calendar Days will begin on the day the Contractor begins On-Site Work as defined in 00110.20.

Add the following subsection:

00180.50(h) Contract Time - There is one Contract Time on this Project as follows:

Complete all Work to be done under the Contract absolutely not later than August 31, 2019.

The Contractor shall complete all Work to be done under the Contract within one hundred and twenty calendar (120) of "Notice to Proceed" or within sixty (60) days of Engineer's approval to begin bypass pumping, whichever occurs later.

00180.85(b)(1) Single Contract Time - Replace this subsection, except for the subsection number and title, with the following:

The Liquidated Damages per Calendar Day* are 15.0 percent of C divided by T as defined in this Section.

C = The Contractor's Bid amount for the Contract.

T = The total Calendar Days between the latest completion date or time listed under 00180.50(h) in the Solicitation Documents and the Bid Opening that will result in the greatest value for T.

* Calendar Day amounts are applicable when the Contract time is expressed on the Calendar Day or fixed date basis.

SECTION 00190 - MEASUREMENT OF PAY QUANTITIES

Comply with Section 00190 of the Standard Specifications.

SECTION 00195 - PAYMENT

Comply with Section 00195 of the Standard Specifications modified as follows:

00195.10 Payment for Changes in Materials Costs - Replace this subsection with the following subsection:

00195.10 Payment for Changes in Materials Costs – There are no changes in payments for escalation/De-Escalation of materials in this Contract.

Additional work required by the Agency will be negotiated on a case by case basis for all changes in materials costs and shall be agreed upon, in writing, before the work is accomplished.

All materials are subject to change in costs and conditions, as specified in subsection 00195.20 Changes in Plans or Character of Work, including but not limited to:

- Steel Materials Price Adjustment
- Asphalt Cement Price Adjustment
- Fuel Price Adjustment

SIXTH ST. SANITARY SEWER REPLACEMENT

The Agency reserves all of its rights under the Contract, including, but not limited to, its rights for suspension of the Work under 00180.70 and its rights for termination of the Contract under 00180.90, and this escalation/de-escalation provision shall not limit those rights.

00195.12 Steel Material Price Escalation/De-Escalation – Remove this subsection in its entirety.

00195.50 (1) Progress Payments - Replace the paragraph that begins with “At the same time each month...” of this subsection with the following:

At the same time each month, the Contractor will make an estimate of the amount and value of the Pay Item Work completed. The Contractor will submit this estimation of quantities to the Engineer for agreement on the number of estimated units completed for unit price Pay Items plus the estimated percentage completed of lump sum Pay Items.

00195.50 (2) Value of Materials on Hand – Replace the paragraph that begins with “The Engineer will...” of this subsection with the following:

The Contractor will also make an estimate of the amount and value of acceptable Materials on hand, i.e., already delivered and stored according to 00195.60(a), to be incorporated into the Work and submit this estimation to the Engineer for agreement for Pay Items for this progress payment.

00195.50(b) Retainage - Replace the paragraph that begins "The amount to be retained..." with the following paragraph:

The amount to be retained from progress payments will be 5% of the value of Work accomplished, and will be retained by the Agency until completion of the Work as specified in (c) below.

00195.50(c) Forms of Retainage - Replace this entire subsection through and including 00195.50(3) Bonds, Securities, and Other Instruments with the following:

The Agency will withhold payment of 5% of all progress payments until completion of the project as is described in (c) below.

Insert the following:

00195.50 (c) Release of Retainage – The Agency will make payment to the Contractor after the Contractor has made application for payment to the Engineer upon issuance of the Third Notification.

00195.50 (e) Withholding Payments – Change (e) to (d) in the title of this subsection.

00195.50 (f) Prompt Payment Policy – Change the (f) to (e) in the title of this subsection.

00195.90(c) No Waiver of Right to Make Adjustment - Replace this subsection, except for the subsection number and title, with the following:

The fact that the Agency has made any measurement, estimate, determination or certification either before or after completion of the Project, Final Acceptance, Agency assumption of possession of the Project Site, determination of satisfactory completion of Pay Items or Work or release of retainage under 00195.50(c) or payment for any part of the Work, shall not prevent either party from:

- Showing the true amount and character of the Work;
- Showing that any measurement, estimate, determination or certification is incorrect;
- Recovering from the other party damages that may have been suffered because the other party failed to comply with the Contract.

SECTION 00196 - PAYMENT FOR EXTRA WORK

Comply with Section 00196 of the Standard Specifications.

SECTION 00197 - PAYMENT FOR FORCE ACCOUNT WORK

Comply with Section 00197 of the Standard Specifications modified as follows:

00197.20(a) General - Replace the paragraph that begins "Except as modified by these..." with the following paragraph:

Except as modified by these provisions, Equipment use approved by the Engineer will be paid at the rental rates given in the most current edition of the EquipmentWatch Cost Recovery (Blue Book) published by EquipmentWatch, a division of Penton Business Media, Inc., and available from EquipmentWatch (phone 1-800-669-3282) (<http://equipmentwatch.com>).

00197.20(c-3) Rate Adjustment Factor - Replace this subsection, except for the subsection number and title, with the following:

The rate adjustment factor used above will be determined by applying only the Model Year Adjustment to the Blue Book Rates. The Regional and User Defined Ownership/Operating Adjustments shall not apply.

00197.20(c-5) Limitations - Delete the paragraph that begins "The Blue Book..."

SIXTH ST. SANITARY SEWER REPLACEMENT

SPECIAL PROVISIONS

WORK TO BE DONE

The Work to be done under this Contract consists of the following:

1. Construct two (2) 48" MH and approximately 365' of 6" PVC pipe connecting each MH to an existing MH.
2. Abandoning two (2) sections of existing 6" sanitary sewer and associated cleanouts.
3. Constructing five (5) service laterals to the new SS.
4. Restore disturbed surfaces as appropriate.

APPLICABLE SPECIFICATIONS

The Specifications that are applicable to the Work on this Project is the 2018 edition of the "Oregon Standard Specifications for Construction".

All number references in these Special Provisions shall be understood to refer to the Sections and subsections of the Standard Specifications bearing like numbers and to Sections and subsections contained in these Special Provisions in their entirety.

CLASS OF PROJECT

This is a Municipal Public Works Project.

SEQUENCE OF WORK

The sequence of the work will be the responsibility of the contractor but connecting the residence at 691 Harrison to the new SS is a priority.

SECTION 00210 - MOBILIZATION

Comply with Section 00210 of the Standard Specifications.

SECTION 00310 - REMOVAL OF STRUCTURES AND OBSTRUCTIONS

Comply with Section 00310 of the Standard Specifications.

SECTION 00410 - COMMON PROVISIONS FOR PIPE LINING

Comply with Section 00410 of the Standard Specifications.

SECTION 00420 – SALVAGING PIPE

Comply with Section 00420 of the Standard Specifications modified as follows:

00420.80 Measurement – No measurement of quantities will be made for salvage pipe or associated equipment.

00420.90 Payment - No payment of quantities will be made for salvage pipe. All salvage pipe and associated equipment is the property and responsibility of the Contractor to dispose of in a location and manner as approved by law.

SECTION 00440 - COMMERCIAL GRADE CONCRETE

Comply with Section 00440 of the Standard Specifications modified as follows:

Add the following subsection:

00440.01 Terminology - According to 00110.05(a), for the purposes of this Contract, the terms "sidewalk ramp" and "sidewalk ramps" shall respectively refer to and shall be read to mean "curb ramp" and "curb ramps".

Add the following subsection:

00440.02 Abbreviations and Definitions:

ASTV – Actual Strength Test Value – See 02001.02 for definition.

00440.12 Proportions of Commercial Grade Concrete - Replace the bullet that begins "Compressive strength..." with the following bullet:

- **Compressive Strength** - ASTV minimum of 3,000 psi at 28 days

SIXTH ST. SANITARY SEWER REPLACEMENT

00440.14(d) Hardened CGC - Add the following to the end of this subsection:

The ASTV at 28 Days is the average compressive strength of the three cylinders tested. Discard all specimens that show definite evidence, other than low strength, of improper sampling, molding, handling, curing, or testing. The average strength of the remaining cylinders shall then be considered the test result.

SECTION 00490 – WORK on EXISTING SEWERS and STRUCTURES

Comply with Section 00490 of the Standard Specifications modified as follows:

00490.42 Service Line Connections to Existing Sanitary Sewers – Add the following sentence to this subsection:

Inserta-Tee is the approved commercial tap to be use on existing sewer mains.

SECTION 02001 - CONCRETE

Comply with Section 02001 of the Standard Specifications modified as follows:

02001.02 Abbreviations and Definitions - Replace this subsection, except for the subsection number and title, with the following:

- ASTV** - Actual Strength Test Value - average of test cylinder compressive strengths
- f'_c - Minimum Specified Compressive Strength at 28 days
- f'_{cr} - Average Compressive Strength Over-design. The average strength required to assure that, with normal variations, the concrete will meet f'_c
- GGBFS** - Ground Granulated Blast Furnace Slag
- HPC** - High Performance Concrete
- HRWRA** - High-Range Water-Reducing Admixture (super-plasticizer)
- PPCM** - Precast prestressed concrete member
- SCM** - Supplementary Cementitious Materials
- SSD** - Saturated Surface-Dry
- w/cm Ratio** - Water-Cementitious Material Ratio
- WRA** - Water Reducing Admixture

Cementitious Materials - Portland cement and supplementary cementitious materials.

High Performance Concrete - Concrete designed for enhanced durability and performance characteristics. High performance concrete is identified on the Plans by the letters "HPC" in front of the concrete class designation (for example, HPC4500 - 1 1/2).

Moderate Exposure - Elevations below 1,000 feet.

Pozzolans - Fly ash, silica fume, and metakaolin.

Severe Exposure - Elevations 1,000 feet and above.

Supplementary Cementitious Materials - Fly ash, silica fume, metakaolin, and ground granulated blast furnace slag.

02001.10 Materials - Replace this subsection, except for the subsection number and title, with the following:

Furnish Materials meeting the requirements of the following:

Aggregates	02690
Cement.....	02010
Chemical Admixtures	02040
Concrete Modifiers.....	02035
Supplementary Cementitious Materials.....	02030
Synthetic Fiber Reinforcing	02045
Water	02020

02001.20(a) Strength - Replace this subsection, except for the subsection number and title, with the following:

Provide concrete meeting the required Classes shown in the Contract Documents. The class of concrete designates the minimum required compressive strength, f'_c at 28 days.

Table 02001-1

Concrete Strength and Water/Cementitious Material (w/cm) Ratio		
Type of Concrete	Strength (PSI)	Maximum w/cm Ratio
Structural	3300	0.50
	3300 (Seal)	0.45
	4000	0.48
	HPC4500	0.40
	5000 and Above	0.40 ¹
	HPC5000 and above	0.40
Drilled Shaft	4000	0.48
Paving	4000	0.44
¹ PPCM's with cast-in-place decks and no entrained air may have w/cm as follows: 5000 psi - 0.48; 5500 psi - 0.44; 6000 psi and up - 0.42		

SIXTH ST. SANITARY SEWER REPLACEMENT

02001.30 Concrete Mix Design - Replace the bullet that begins "Cementitious material with modifiers proportioned according..." with the following bullet:

Cement with SCM proportioned according to 02001.31(b) and with trial batches performed to demonstrate that the proposed alternate mix design provides a maximum of 1,000 coulombs at 90 days when tested according to AASTHO T 277.

02001.31 Concrete Constituents - Replace this entire subsection with the following subsection:

02001.31 Concrete Constituents:

(a) Portland Cement - Use AASHTO M 85 or ASTM C150, Type I or II cement for structural or paving concrete. Use AASHTO M 85 or ASTM C150, Type III cement for precast prestressed concrete. Provide all cement from the QPL.

(b) Supplementary Cementitious Materials - SCM may be used separately or in combinations up to the specified maximum percentage by mass according to the following:

Separate SCM	Maximum
Fly Ash + Other Pozzolans	25%
GGBFS	50%
Silica Fume	5%

Combined SCM	Maximum
Fly Ash + Other Pozzolans + GGBFS + Silica Fume	50%*
Fly Ash + Other Pozzolans + Silica Fume	30%*

* Fly ash + other pozzolans shall constitute no more than 25% and silica fume shall constitute no more than 5% of the total weight of cementitious materials.

When silica fume is added to truck mixed concrete, mix the batch a minimum of 100 revolutions at the mixing speed specified by the manufacturer before leaving the batch plant.

(c) Blended Hydraulic Cement - Blended hydraulic cement may be used subject to the limits of 02001.31(b) and 02010.20.

(d) Chemical Admixtures - Use chemical admixtures according to the manufacturer's recommendations. Use WRA in all seal concrete and in Class 5000 concrete or greater. Use HRWRA in all HPC.

Use a superset extender from the QPL in all concrete for bridge decks. Use an appropriate amount to extend the initial set time of the concrete by 90 minutes.

(e) Aggregate - If the nominal maximum size of the coarse Aggregate is not included as a part of the class of concrete, or shown on the Plans, any size from 1 1/2-inch to 3/8-inch nominal maximum size Aggregate may be used according to ACI guidelines except:

Use 1 1/2 inch nominal maximum size Aggregates in bridge deck concrete.

Use 1 1/2 inch nominal maximum size Aggregates in paving concrete unless otherwise indicated.

Use 3/8 inch nominal maximum size Aggregates in drilled shafts unless otherwise indicated.

Proportion all HPC for a minimum coarse Aggregate absolute solid volume according to Table 02001-4:

Table 02001-4

Absolute Solid Volume	
Maximum Nominal Aggregate Size	Cu. Yd. (Aggregate) / Cu. Yd. (Concrete)
3/8"	0.36
1/2"	0.38
3/4"	0.40
1"	0.42
1 1/2"	0.44

Two or more Aggregate products or sources meeting Specifications may be blended to improve concrete properties. Blending non-specification Aggregate Materials, except for gradation, with specification Materials is not allowed.

02001.35 Required Submittals for Mix Designs - Replace this entire subsection with the following subsection:

02001.35 Required Submittals for Mix Designs - Submit the following information for each concrete mix design:

(a) Supplier's Information - Provide the supplier's unique mix design identification number and batch plant location.

(b) Mix Design Constituent Proportions:

- Weight per cubic yard (pounds per cubic yard) of cement, SCM, fine Aggregates and coarse Aggregates (SSD), mix water, concrete modifiers, and chemical admixtures
- Absolute volumes of cement, SCM, fine Aggregates and coarse Aggregates (SSD), mix water, air content, concrete modifiers, and chemical admixtures
- Dosage rates for chemical admixtures (ounces per cubic yard)
- w/cm ratio including all chemical admixtures

(c) Aggregates - Identify the Aggregate source by the ODOT source number. Report current values of the following:

- Bulk specific gravities (SSD)
- Fine Aggregate absorptions
- Coarse Aggregate absorptions
- Dry-rodded density of coarse Aggregates

SIXTH ST. SANITARY SEWER REPLACEMENT

Average stockpile gradations

Fineness modulus of sand used in the mix design calculations

(d) Cement - For each cement used, provide the following:

- Manufacturer
Brand name
Type
Source or location plant
QPL product number

(e) SCM - For each SCM used, provide the following:

- Manufacturer
Brand name
Source
Class
QPL product number

(f) Concrete Modifiers - For each concrete modifier used, provide the following:

- Manufacturer
Brand name
QPL product number

(g) Admixtures - For each admixture used, identify the following:

- Manufacturer
Brand name
Design dosage rate
QPL product number

(h) Synthetic Fiber Reinforcing - For each synthetic fiber reinforcing used, provide:

- Manufacturer
Brand name
Design dosage rate
QPL product number

(i) Water - Identify the source of water to be used and provide a certificate of compliance certifying that the water meets the requirements of 02020.10.

(j) Plastic Concrete Tests - Report the temperature, slump, density, air content, yield, and w/cm ratio of the trial batch or the average of these values for the cylinder sets presented for evaluation of a current mix design.

For drilled shaft concrete, report the following additional information:

- The total time estimate from initial batching through drilled shaft placement, including haul time, placing concrete, and temporary casing extraction.

Initial slump test results and subsequent results at 15-minute intervals, verifying a minimum slump of 4 inches is maintained for the total time estimated for drilled shaft placement, including temporary casing extraction. Report data in a table or graph format.

(k) Compressive Strength Test Results - Report the individual test results and the ASTV of cylinders from the trial batch for new mix designs. For current designs, provide the individual tests and the average of the cylinder sets presented for evaluation.

(l) Strength Analysis - Provide an analysis, showing all calculations, demonstrating that the mix design meets the requirements of 02001.33.

(m) Quality Control Personnel - Provide the name and certification number of the CCT who prepared the mix design, the QCT who performed the plastic concrete tests and cast the test cylinders, the CSTT who tested the cylinders, and the ODOT certification number of the laboratory where the cylinders were tested.

APPENDIX “B”

Submittals of the following shall be delivered to the Engineer in accordance with Article D(13) of the General Conditions. *NOTE: This list is intended to be a useful guide to the Contractor and not necessarily a definitive list of all items that a submittal may be required on. If requested by the Engineer additional item(s) shall be delivered in the format outlined for review and approval.*

General Conditions:

- Signed Contract
- Signed Notice To Proceed
- Contractor’s personnel’s contact information & 24-hour emergency number
- Contractors Insurance Certificate(s)
- Schedule of work in flow chart format
- List of Subcontractors
- Copies of government permits (building, electrical, plumbing ODOT right of way, etc.)
- Performance, Payment, Labor and Materials Bonds

Division 2 – Sitework:

- Dust control plan

Division 3 – Concrete:

- Concrete mix design(s)
- Non shrink grout/dry pack
- Debris dumping site location/permit
- CDF mix design.

Division 4 – Streets – NOT USED

- Asphalt mix design

Division 5 – Water – NOT USED

Division 6 – Sanitary Sewers

- PVC Pipe and fittings
- Manhole lid
- Manhole frame and cover

Division 7 – Storm Sewers – NOT USED

Division 8 – Structures – NOT USED

Division 9 – Miscellaneous – NOT USED

Division 10 – Equipment

- Gages
- Valves
- SS Pipe and fittings
- DI Pipe and Fittings

Project No. 2020-013-08

SIXTH ST. SANITARY SEWER REPLACEMENT

Page 1 of 2

Required Submittal Checklist

APPENDIX “B”

- Pipe and fittings

**CITY OF WOODBURN
SANTIAM LIFT STATION REMOVAL**

PART V

PLANS

DRAWINGS

- G-1 COVER SHEET
- C-1 PLAN AND PROFILE 700 BLOCK
- C-2 PLAN AND PROFILE 900 BLOCK
- 4-10 DETAILS

SIXTH STREET SANITARY SEWER REPLACEMENT

PROJECT No. 2020-013-08

BID No. 2021-04

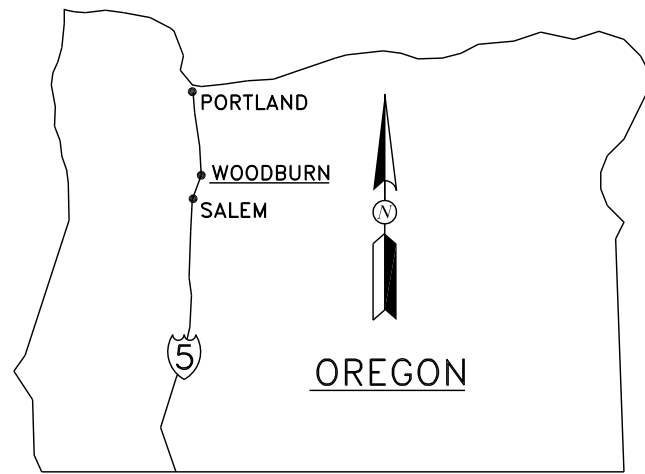

VICINITY MAP
NTS

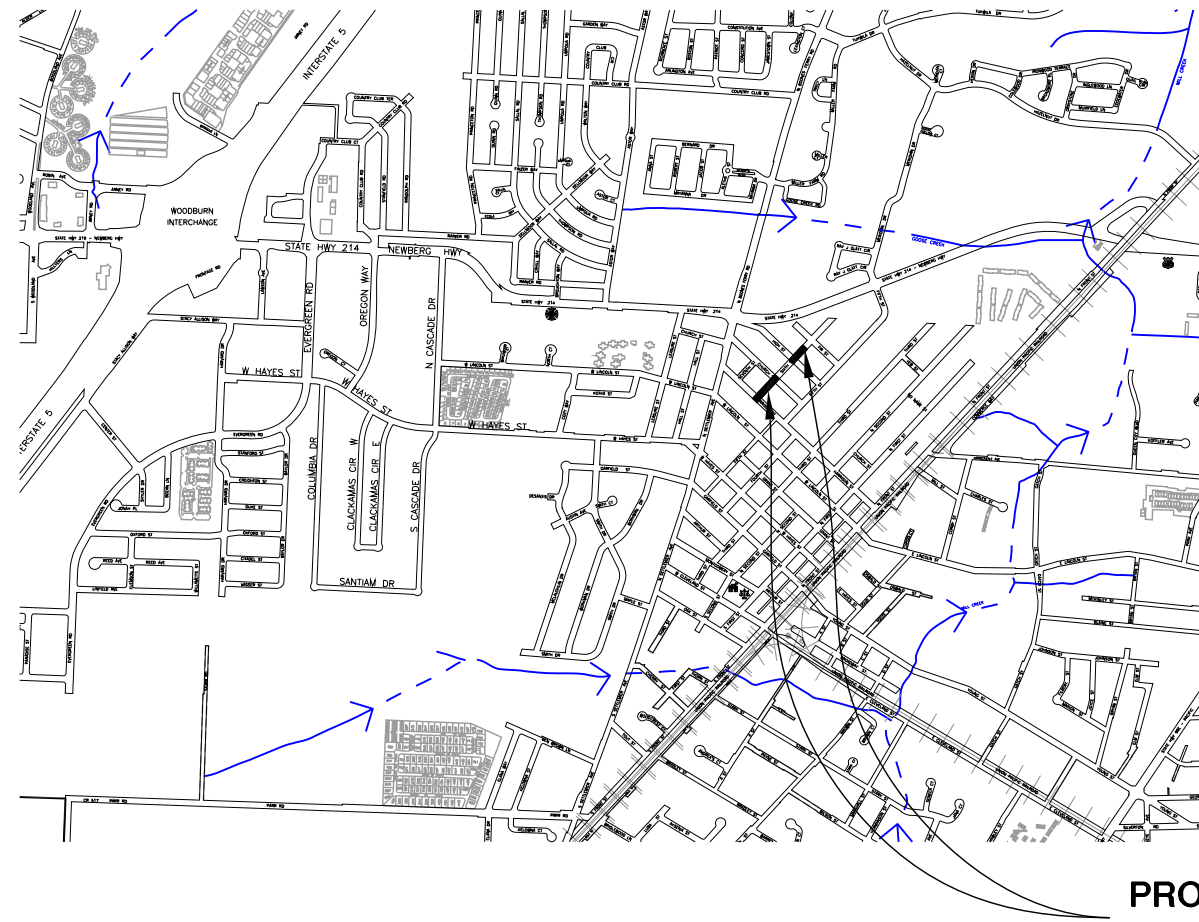

LOCATION MAP
NTS

PROJECT LOCATION
700 AND 900 BLOCKS OF
SIXTH STREET

INDEX OF DRAWINGS

SHEET NO.	TITLE
1	TITLE SHEET
2	CONSTRUCTION NOTES
3	PLAN AND PROFILE 700 BLOCK
4	PLAN AND PROFILE 900 BLOCK
5-12	DETAILS

PLOT DATE: 12.15.2020 3:36 PM

<p>THIS BAR IS ONE-INCH ON ORIGINAL DRAWING.</p>	<p>DESIGNED: <u>PJG</u> DRAWN: <u>PJG</u> REVIEWED: <u>DG</u> APPROVED: <u>XXX</u> HORIZONTAL DATUM: <u>LOCAL</u> VERTICAL DATUM: <u>LOCAL</u></p>		<p>REVISIONS:</p> <table border="1" style="width: 100%; height: 40px;"> <tr> <td style="width: 50px;"> </td> <td> </td> </tr> </table>			<p>SIXTH STREET SANITARY SEWER REPLACEMENT</p> <p>TITLE SHEET</p>	<p>BID SET</p> <p>PROJECT NO. 2020-013-08</p> <p>DATE DECEMBER 2020</p> <p>SHEET NO. 1</p>

GENERAL NOTES:

- ALL MATERIALS AND WORKMANSHIP SHALL CONFORM TO THE 2018 EDITION OF THE OREGON STANDARD SPECIFICATIONS FOR CONSTRUCTION AND ALL APPLICABLE LOCAL, STATE, AND FEDERAL CODES AND REGULATIONS.
- A COPY OF THESE APPROVED PLANS AND DETAILS SHALL BE ON-SITE DURING CONSTRUCTION.
- ANY REVISIONS MADE TO THESE PLANS MUST BE REVIEWED AND APPROVED BY THE AGENCY PRIOR TO ANY IMPLEMENTATION IN THE FIELD.
- THE CONTRACTOR SHALL HAVE ALL UTILITIES VERIFIED ON THE GROUND PRIOR TO ANY CONSTRUCTION. CALL ONE CALL LOCATE AT LEAST 48 HOURS IN ADVANCE. THE PUBLIC WORKS DEPARTMENT AND ENGINEERING DIVISION SHALL BE CONTACTED IMMEDIATELY IF A CONFLICT EXISTS (503-982-5240).
- THE CONTRACTOR SHALL AT ALL TIMES ABIDE BY APPLICABLE SAFETY RULES OF OR-OSHA AND IN PARTICULAR THOSE PERTAINING TO ADEQUATE SHORING AND TRENCH PROTECTION.
- THE CONTRACTOR SHALL INSTALL AND MAINTAIN ALL REQUIRED EROSION CONTROL MEASURES IN ACCORDANCE WITH THE NOTES AND PLANS BELOW.
- EXISTING UTILITY LOCATIONS ARE APPROXIMATE ONLY, EXACT LOCATIONS TO BE DETERMINED IN THE FIELD BY THE CONTRACTOR. THE CONTRACTOR SHALL BE RESPONSIBLE FOR LOCATING ALL UTILITIES NOT SHOWN ON THE PLANS. THE CONTRACTOR SHALL COORDINATE WORK WITH ALL UTILITY COMPANIES AS REQUIRED TO COMPLETE THE PROJECT.
- ALL DAMAGE CAUSED BY THE CONTRACTOR SHALL BE RESTORED TO AN "AS GOOD OR BETTER" CONDITION.
- PROPERTY OWNERS/RESIDENTS SHALL HAVE ACCESS TO THEIR PROPERTIES AT ALL TIMES DURING CONSTRUCTION ACTIVITIES. CONTRACTOR TO MAKE ALLOWANCES FOR ANY LOCAL DELIVERIES AND/OR GARBAGE PICK-UP. PROVIDE WRITTEN NOTICE TO ALL PROPERTY OWNERS AT LEAST 2 WORK DAYS IN ADVANCE OF WORK IN AND OR CROSSING DRIVEWAYS.
- CONTRACTOR MAY PROCURE WATER FROM A CITY FIRE HYDRANT ONLY AFTER APPROVAL OF THE ENGINEER, INSTALLATION OF BACKFLOW PREVENTOR BY CITY DRINKING WATER SECTION CREWS, AND PAYMENT OF APPROPRIATE FEES TO THE WATER SECTION, IF REQUIRED.
- ONLY CITY STAFF CAN OPERATE LIVE WATER VALVES AND FIRE HYDRANTS. NOTIFY THE CITY OF WOODBURN PRIOR TO THE NEED FOR THE OPERATION OF LIVE WATER LINES.
- CONTRACTOR SHALL REMOVE ALL EXISTING SIGNS, MAILBOXES, FENCES, LANDSCAPING, AND ETC. AS REQUIRED TO AVOID DAMAGE DURING CONSTRUCTION AND REPLACE THEM TO EXISTING OR BETTER CONDITION WHEN WORK IS COMPLETED. MAILBOXES SHALL BE TEMPORARILY RELOCATED. MEANS, METHODS AND LOCATIONS AS APPROVED BY THE ENGINEER.
- THE CONTRACTOR SHALL LOCATE AND MARK ALL EXISTING PROPERTY AND STREET MONUMENTS PRIOR TO CONSTRUCTION. ANY MONUMENTS DISTURBED DURING CONSTRUCTION OF THE PROJECT SHALL BE REPLACED AND RECORDED BY A REGISTERED LAND SURVEYOR AT THE CONTRACTOR'S EXPENSE.

EROSION AND SEDIMENT CONTROL (ESC) NOTES:

- CONTRACTOR SHALL BE RESPONSIBLE FOR PROPER INSTALLATION AND MAINTENANCE OF ALL EROSION AND SEDIMENT CONTROL MEASURES, IN ACCORDANCE WITH LOCAL, STATE, AND FEDERAL REGULATIONS.
- THE IMPLEMENTATION OF THESE ESC PLANS AND CONSTRUCTION, MAINTENANCE, REPLACEMENT, AND UPGRADING OF THESE ESC FACILITIES IS THE RESPONSIBILITY OF THE CONTRACTOR UNTIL ALL CONSTRUCTION IS COMPLETED AND APPROVED BY THE LOCAL JURISDICTION, AND VEGETATION/LANDSCAPING IS ESTABLISHED.
- THE ESC FACILITIES DESCRIBED ON THIS PLAN MUST BE CONSTRUCTED IN CONJUNCTION WITH ALL CLEARING AND GRADING ACTIVITIES, AND IN SUCH A MANNER AS TO INSURE THAT SEDIMENT AND SEDIMENT LADEN WATER DOES NOT ENTER THE DRAINAGE SYSTEM, ROADWAYS, OR VIOLATE APPLICABLE WATER STANDARDS.
- THE ESC FACILITIES SHOWN ON THIS PLAN ARE MINIMUM REQUIREMENTS FOR ANTICIPATED SITE CONDITIONS. DURING CONSTRUCTION PERIOD, THESE ESC FACILITIES SHALL BE UPGRADED AS NEEDED FOR UNEXPECTED STORM EVENTS AND TO ENSURE THAT SEDIMENT AND SEDIMENT LADEN WATER DOES NOT LEAVE THE SITE.
- THE ESC FACILITIES SHALL BE INSPECTED DAILY BY THE APPLICANT/CONTRACTOR AND MAINTAINED AS NECESSARY TO ENSURE THEIR CONTINUED FUNCTIONING.
- AT NO TIME SHALL SEDIMENT BE ALLOWED TO ACCUMULATE MORE THEN 1/3 THE BARRIER HEIGHT. ALL CATCH BASINS AND CONVEYANCE LINES SHALL BE CLEANED PRIOR TO PAVING. THE CLEANING OPERATIONS SHALL NOT FLUSH SEDIMENT-LADEN WATER INTO THE DOWNSTREAM SYSTEM.
- STORM DRAIN INLETS, BASINS, AND AREA DRAINS SHALL BE PROTECTED UNTIL PAVEMENT SURFACES ARE COMPLETED AND/OR VEGETATION IS RE-ESTABLISHED.
- PAVEMENT SURFACES AND VEGETATION ARE TO BE PLACED AS RAPIDLY AS POSSIBLE.
- SEEDING SHALL BE PERFORMED NO LATER THAN SEPTEMBER 1 FOR EACH PHASE OF CONSTRUCTION.
- IF THERE ARE EXPOSED SOILS OR SOILS NOT FULLY ESTABLISHED FROM OCTOBER 1ST THROUGH APRIL 30TH, THE WET WEATHER EROSION PREVENTION MEASURES WILL BE IN EFFECT.
- THE DEVELOPER SHALL REMOVE ESC MEASURES WHEN VEGETATION IS FULLY ESTABLISHED.
- ANY SOIL OR DEBRIS TRANSPORTED ONTO ROADWAYS AND SIDEWALKS SHALL BE REMOVED. DEPOSITS SHALL BE COMPLETELY REMOVED BY SHOVELING AND/OR SWEEPING. WASHING SHALL NOT BE UTILIZED UNLESS SPECIFICALLY APPROVED IN WRITING BY THE CITY OF WOODBURN.
- IF BMPS (BEST MANAGEMENT PRACTICES) SHOWN ARE UTILIZED BUT ARE INSUFFICIENT TO PREVENT SEDIMENT FROM REACHING WATER BODIES, ADJACENT PROPERTIES, OR PUBLIC RIGHTS-OF-WAY; ADDITIONAL BMPS SHALL BE IMPLEMENTED IMMEDIATELY TO PREVENT FURTHER ENCROACHMENT OF SEDIMENT.
- STABILIZED AREAS SHALL BE PROVIDED FOR EMPLOYEE PARKING AND STORAGE OF CONSTRUCTION MATERIALS. ERODABLE STOCKPILES OF EARTHEN MATERIALS, SUCH AS TOPSOIL, SILTY AND CLAYEY SOILS; AND LANDSCAPE MATERIALS SHALL BE COVERED WHEN NOT BEING INCORPORATED IN THE WORK. EROSION CONTROL BMPS SHALL BE UTILIZED AS NECESSARY TO PREVENT SEDIMENT-LADEN RUNOFF FROM LEAVING OR SEDIMENT BEING TRANSPORTED FROM THESE AREAS FROM VEHICLE ACTIVITY.

- ALL TRUCKS LEAVING THE SITE WITH EXCAVATION SPOILS MUST BE INSPECTED FOR WATER SEEPAGE. IF SATURATED SOILS ARE A PROBLEM, WATERTIGHT TRUCKS MUST BE USED OR LOADS SHALL BE DRAINED, ON-SITE, SO THAT WATER SEEPING FROM THE SOIL CANNOT DRAIN FROM THE VEHICLE.
- CONSTRUCTION SHALL NOT BE CONSIDERED COMPLETE AND ACCEPTABLE UNTIL ALL DISTURBED SOIL SURFACES HAVE BEEN PROTECTED FROM EROSION AND WITH PERMANENT LANDSCAPING, COVERING WITH IMPERVIOUS SURFACES, RESTORED TO ORIGINAL UNDISTURBED CONDITION OR PERMANENTLY STABILIZED.
- VEGETATED STABILIZATION AND LANDSCAPING SHALL BE FERTILIZED, WATERED AND MAINTAINED TO INSURE THAT GROWTH OF VEGETATION IS ESTABLISHED AND SUSTAINED.
- PLACE GRASS SEED OVER BARREN SOIL; 80/20 BLEND OF DWARF PERENNIAL RYE AND CREEPING RED FESCUE, MIN. 100#/ACRE. APPLY 20-10-10 FERTILIZER IN ACCORDANCE WITH SUPPLIER'S RECOMMENDATIONS.

GRADING AND PAVING NOTES:

- IMMEDIATELY FOLLOWING FINE GRADING OPERATIONS, COMPACT AND PROOF ROLL SUBGRADE AREAS TO ACHIEVE AT LEAST 95% OF MAXIMUM DENSITY FOR A 9" DEPTH PER AASHTO T-99. EMBANKMENTS OR FILLS ARE TO BE CONSTRUCTED IN 6" MAXIMUM LIFTS, WITH EACH LIFT BEING COMPACTED TO 95% MAXIMUM OF DENSITY PRIOR TO PROCEEDING WITH THE NEXT LIFT. AREAS RECEIVING STRUCTURAL FILL ARE TO BE TESTED BY A QUALIFIED TESTING LAB.
- AGGREGATE BASE ROCK SHALL BE 3/4"-0 CRUSHED ROCK. AGGREGATE BASE IS TO BE COMPACTED IN 6" MAXIMUM LIFTS TO 95% OF MAXIMUM DRY DENSITY PER AASHTO T-99.
- THE LIFTS OF ASPHALT CONCRETE ARE TO BE CLASS AS CALLED OUT ON PLANS A.C. PER ODOT SPECIFICATIONS. CONTRACTOR IS TO PROVIDE THE OWNER WITH A PAVING MIX CERTIFICATE OF COMPLIANCE FROM THE ASPHALT PAVEMENT PLANT. PLACE ACP ACCORDING TO SECTION 00744 - ASPHALT CONCRETE PAVEMENT OF THE OREGON STANDARD SPECIFICATIONS FOR CONSTRUCTION.
- INSPECTION OF SUBGRADE, BASE ROCK, AND A.C. WILL BE MADE BY AN QUALIFIED INDEPENDENT TESTING LAB EMPLOYED BY THE AGENCY.
- ALL MATERIALS, INSTALLATION, TEST, AND INSPECTIONS ARE TO BE IN STRICT ACCORDANCE WITH THE AGENCY STANDARDS.
- SAWCUT STRAIGHT MATCHLINES TO CREATE A BUTT JOINT BETWEEN THE EXISTING PAVEMENT AND NEW PAVEMENT. APPLY PRIME COAT AT JOINT SURFACES AND SAND SEAL ALL NEW PAVEMENT JOINTS.

WET WEATHER MEASURES:

- THE MEASURES FOR WET WEATHER CONDITIONS ARE ONE OF THE FOLLOWING OR COMBINATION TO PREVENT SOIL EROSION: ESTABLISHED GRASS, 2" MIN. STRAW MULCH COVER, EROSION CONTROL BLANKETS WITH ANCHORS, 6-MIL PLASTIC SHEET COVER OR SEDIMENT TRAP OR POND.
- AS THE WET WEATHER APPROACHES MORE EROSION CONTROL MEASURES (AS REQUIRED BY CONSTRUCTION INSPECTOR) MAY BE NECESSARY TO REDUCE EROSION.

DEWATERING NOTES:

- CONSTRUCT, MAINTAIN AND OPERATE DEWATERING ACCORDING TO SECTION 00405.43 OF THE OREGON STANDARD SPECIFICATIONS FOR CONSTRUCTION AND TO THE SPECIAL PROVISIONS AND ADDITIONS LISTED BELOW.
- CONTRACTOR IS SOLELY RESPONSIBLE FOR COSTS, DESIGN, INSTALLATION AND MAINTENANCE OF DEWATERING SYSTEMS NEEDED FOR CONTROLLING GROUNDWATER.
- SUFFICIENT PUMPING EQUIPMENT AND MACHINERY, IN GOOD WORKING CONDITION, FOR ALL ORDINARY EMERGENCIES, INCLUDING POWER OUTAGES, AND COMPETENT WORKMEN FOR THE OPERATION OF THE PUMPING EQUIPMENT, SHALL BE AVAILABLE AT ALL TIMES.
- DEWATERING EQUIPMENT SHALL OPERATE AT ALL TIMES UNLESS WRITTEN AUTHORIZATION IS RECEIVED FROM THE ENGINEER.
- CONTROL OF GROUNDWATER SHALL BE SUCH THAT SOFTENING OF THE BOTTOM OF EXCAVATIONS OR FORMATIONS OF "QUICK" CONDITIONS OR BOILS DURING EXCAVATION SHALL BE PREVENTED. DEWATERING SYSTEMS SHALL BE DESIGNED AND OPERATED SO AS TO PREVENT REMOVAL OF THE NATURAL SOILS.
- EXCAVATION FOR AND INSTALLATION OF PIPES AND PLACEMENT OF TRENCH EMBANKMENT SHALL BE KEPT FREE OF WATER. CONTROL SURFACE RUN-OFF SO AS TO PREVENT ENTRY AND COLLECTION OF WATER IN EXCAVATIONS. THE STATIC WATER LEVEL SHALL BE DRAWN DOWN A MINIMUM OF 1 FOOT BELOW THE BOTTOM OF EXCAVATIONS WITHOUT DISTURBANCE TO THE STATE OF THE FOUNDATION SOILS.
- SUBMIT TO THE ENGINEER A STATEMENT OF THE METHOD OF INSTALLATION AND DETAILS OF THE PROPOSED DEWATERING SYSTEM FOR APPROVAL PRIOR TO ANY INSTALLATIONS.
- OPEN AND CASED SUMPS SHALL NOT BE USED AS PRIMARY DEWATERING FOR EXCAVATIONS DEEPER THAN 3 FEET BELOW THE STATIC WATER TABLE UNLESS IT CAN BE DEMONSTRATED TO BE SUCCESSFUL TO THE SATISFACTION OF THE ENGINEER.
- COMPLY WITH OREGON DEPARTMENT OF ENVIRONMENTAL QUALITY'S REQUIREMENTS FOR DEWATERING USING DECANT TANKS THAT MEET OR EXCEED THE DISCHARGE CRITERIA FOR TURBIDITY.

SANITARY SEWER NOTES:

- SEWER PIPE AND FITTINGS TO BE PVC GRAVITY SEWER PIPE CONFORMING TO ASTM F679, SDR 35 WITH RUBBER RING TYPE JOINTS CONFORMING WITH ASTM D-3212. SUBMIT CERTIFICATE OF COMPLETION OF 95% MANDREL TEST ON ALL PIPES AFTER COMPACTION.
- PIPE BEDDING, PIPE ZONE MATERIALS SHALL BE AS SPECIFIED ON THE PLANS AND THE CITY OF WOODBURN'S SPECIFICATIONS.
- SEWER MAINS TO BE AIR TESTED FOLLOWING TRENCH BACKFILL AND COMPACTION. VIDEO INSPECTION AND 95% MANDREL TEST PER APWA 303.3.11 REQUIRED FOR ALL SANITARY SEWERS.
- SETTLEMENT OF THE FINISHED SURFACE WITHIN THE WARRANTY PERIOD SHALL BE CONSIDERED TO BE A RESULT OF IMPROPER COMPACTION AND SHALL BE PROMPTLY REPAIRED BY THE CONTRACTOR AT NO EXPENSE TO THE OWNER.
- ALL AC SAWCUT LINES SHALL BE STRAIGHT. ALL EDGES SHALL BE SEALED AND SANDED UPON COMPLETION.
- SEWER AND WATERLINE CROSSINGS MUST MEET THE REQUIREMENTS OF OAR 333-061-0050(9).
- SANITARY SEWER TV REPORTS SHALL BE RECORDED WITH VIDEO INSPECTION USING THE LATEST VERSION OF NASSCO'S PACP/MACP. FURNISH RECORDINGS ON NASSCO'S PACP/MACP PROGRAM AND INVENTORY SHEETS ON CD INCLUDING A TEST FILE TO INDICATE THE PROJECT NUMBER AND NAME, DATE OF INSPECTION, PIPE SEGMENT NUMBER, CONTRACTOR'S NAME AND WHETHER IT IS A PRE-CONSTRUCTION OR POST-CONSTRUCTION VIDEO, FILENAMES, AND DESCRIPTION OF THE FILE CONTENTS.



CALL BEFORE YOU DIG!
1-800-332-2344

ATTENTION:
OREGON LAW REQUIRES CONTRACTOR TO FOLLOW RULES ADOPTED BY THE OREGON UTILITY NOTIFICATION CENTER. THOSE RULES ARE SET FORTH IN OAR 952-001-0010 THROUGH OAR 952-001-0090. YOU MAY OBTAIN COPIES OF THE RULES BY CALLING THE CENTER. (NOTE: THE TELEPHONE NUMBER FOR THE OREGON UTILITY NOTIFICATION CENTER IS 503.232.1987)

THIS BAR IS ONE-INCH ON ORIGINAL DRAWING.



DESIGNED: PG
DRAWN: PG
REVIEWED: DG
APPROVED: DG
HORIZONTAL DATUM: LOCAL
VERTICAL DATUM: LOCAL

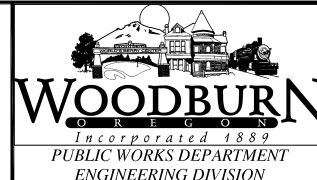

REVISIONS:	

SIXTH STREET SANITARY SEWER REPLACEMENT

CONSTRUCTION NOTES

PROJECT NO.
2020-013-08

DATE
DEC. 2020

SHEET NO.

2

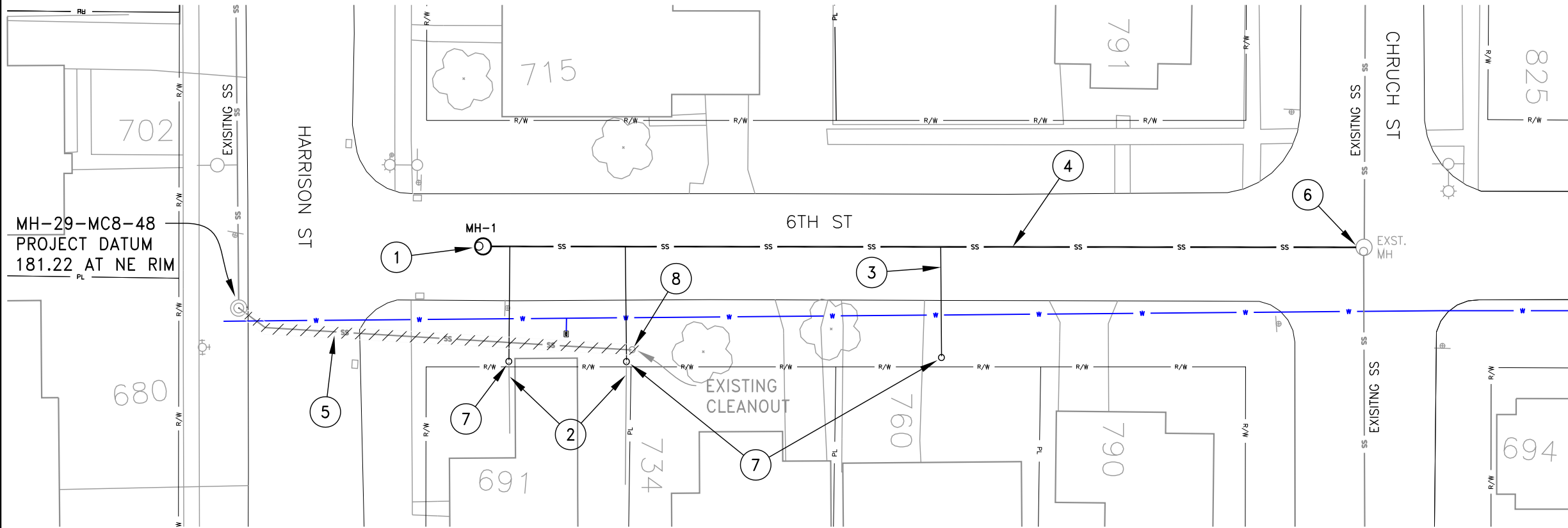

PLAN VIEW
SCALE: 1"=30'

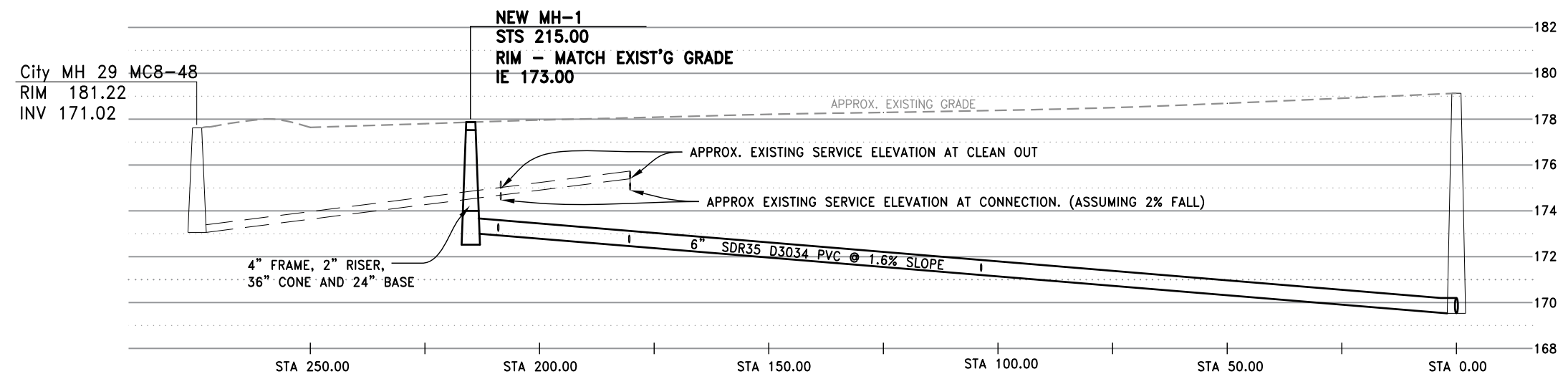

PROFILE VIEW
HORIZONTAL SCALE: 1"=30'
VERTICAL SCALE: 1"=6'

PLAN NOTES:

1. INSTALL NEW Ø48" MANHOLE PER CITY STANDARD DETAIL 6510-3.
2. EXTEND AND CONNECT TWO SERVICE LATERALS TO NEW 6" SANITARY SEWER. APPLICANT TO VERIFY EXISTING SERVICE LATERAL SIZE AND ELEVATION PRIOR TO CONSTRUCTION OF NEW SEWER MAIN.
3. INSTALL 4" SEWER SERVICE CONNECTION LATERAL FOR FUTURE. INSTALL PLUG BEHIND NEW CLEANOUT. SEE CITY STANDARD DETAIL 6200-3. VERIFY WITH CITY INSPECTOR.
4. CONSTRUCT APPROXIMATELY 215 LF OF 6" 3034 PVC SANITARY SEWER PIPE. TYPE 'D' BEDDING, CLASS 1 BACKFILL. SEE DETAILS 3800-1 & 3800-2.
5. ABANDON IN PLACE APPROXIMATELY 100' OF 6" CONCRETE SANITARY SEWER. FILL PIPE WITH CDF.
6. CONNECT NEW 6" PVC SANITARY SEWER TO EXISTING MANHOLE. SEE ODOT STANDARD DRAWING RD345 - PIPE TO MANHOLE CONNECTION. MANHOLE TO BE CORE DRILLED FOR CONNECTION.
7. CONSTRUCT SERVICE AND CLEAN OUT PER DETAIL 6200-3 AT ALL SERVICE LATERALS PER PLAN. VERIFY CLEAN OUT LOCATION WITH CITY INSPECTOR.
8. DEMO EXISTING CLEAN OUT.

GENERAL NOTES:

1. CONTRACTOR TO VERIFY ELEVATIONS AND REPORT TO ENGINEER IF SUBSTANTIALLY DIFFERENT THAN PLANS.
2. CONTRACTOR SHALL BE RESPONSIBLE FOR ALL SEWER BYPASS ACTIVITIES THAT MAY BE REQUIRED DURING THE CONSTRUCTION OF THE NEW SEWER MAIN & SANITARY SEWER SERVICES.
3. FOR STREET CUT, TRENCH BACKFILL, TRENCH BEDDING AND PIPE ZONE SEE CITY STANDARD DETAILS 3800-1, 3800-2, 3800-5 & 6200-4.
4. RESTORE SITE TO AS GOOD OR BETTER CONDITION. THIS INCLUDES REPLACING CURBS, ASPHALT AND RESEEDING.
5. PROVIDE WORK ZONE TRAFFIC CONTROL IN ACCORDANCE WITH SECTION 00220 AND 00225 AND AS AMENDED BY SPECIAL PROVISIONS.

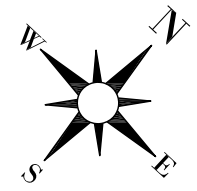

PLOT DATE: December 15, 2020

<p>THIS BAR IS ONE-INCH ON ORIGINAL DRAWING.</p>	<p>DESIGNED: PG DRAWN: PG REVIEWED: DG APPROVED: DG HORIZONTAL DATUM: LOCAL VERTICAL DATUM: LOCAL</p>		<p>REVISIONS:</p> <table border="1" style="width: 100%; border-collapse: collapse;"> <tr><td> </td><td> </td></tr> <tr><td> </td><td> </td></tr> <tr><td> </td><td> </td></tr> </table>							<p>SIXTH STREET SANITARY SEWER REPLACEMENT</p> <p>700 BLOCK PLAN AND PROFILE</p>	<p>PROJECT NO. 2020-013-08</p> <p>DATE DEC. 2020</p> <p>SHEET NO. 3</p>

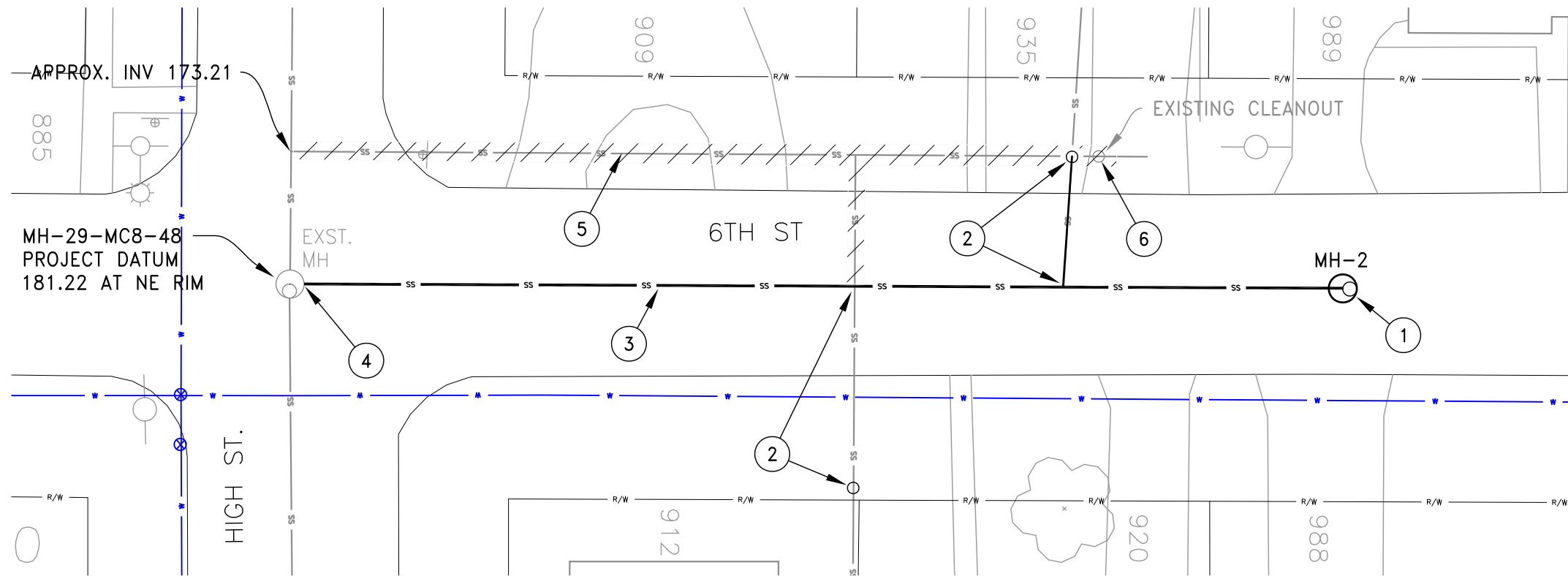

PLAN VIEW
SCALE: 1"=20'

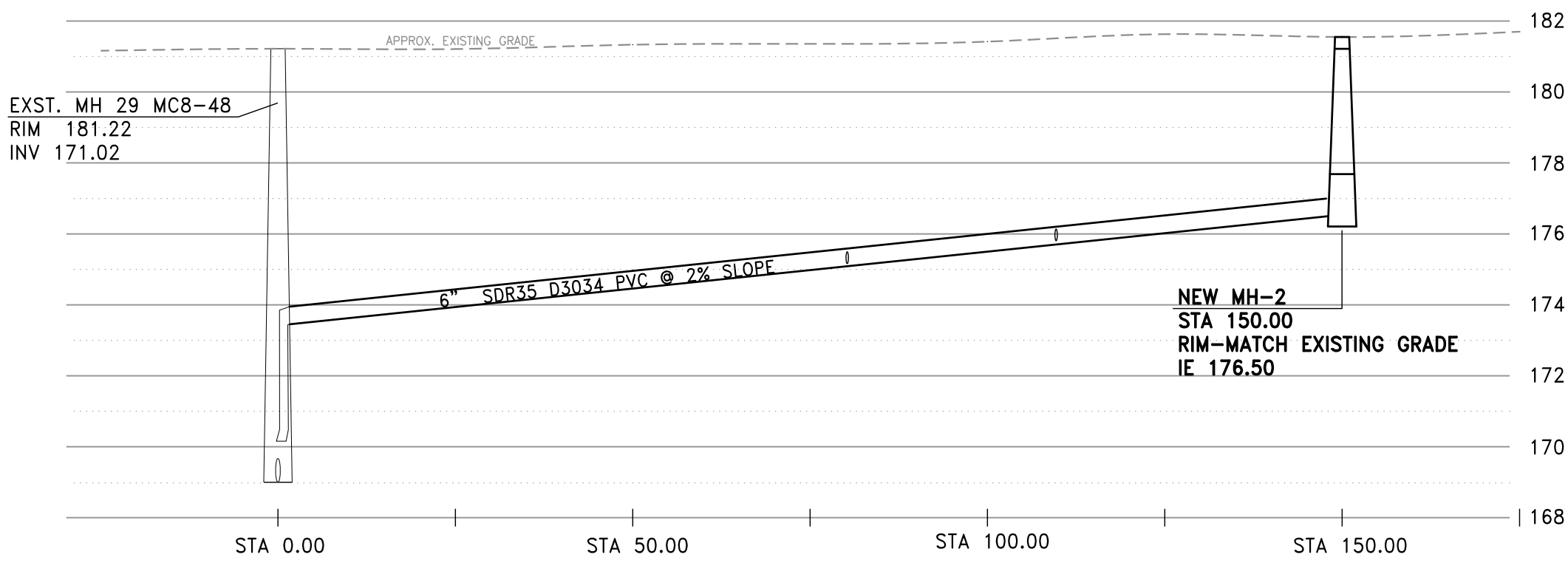

PROFILE VIEW
HORIZONTAL SCALE: 1"=20'
VERTICAL SCALE: 1"=4'

- PLAN NOTES:**
1. CONSTRUCT NEW $\phi 48$ " MANHOLE PER CITY STANDARD DETAIL 6510-3.
 2. INSTALL NEW CLEAN OUT AND CONNECT EXISTING LATERAL TO NEW MAIN PER DETAIL 6200-3. VERIFY NEW CLEAN OUT LOCATION WITH CITY INSPECTOR. APPLICANT TO VERIFY EXISTING SERVICE LATERAL SIZE AND ELEVATION PRIOR TO CONSTRUCTION OF NEW SEWER MAIN.
 3. CONSTRUCT APPROXIMATELY 150 LF OF 6" 3034 PVC SANITARY SEWER. TYPE 'D' BEDDING, CLASS 1 BACKFILL. SEE DETAILS 3800-1 & 3800-2.
 4. CONNECT NEW 6" SEWER MAIN TO EXISTING MANHOLE AND INSTALL INSIDE DROP PER "INSIDE DROP DETAIL". MANHOLE TO BE CORE DRILLED FOR CONNECTION.
 5. ABANDON EXISTING 6" SANITARY SEWER IN PLACE. FILL PIPE WITH CDF.
 6. DEMO EXISTING CLEAN OUT.

- GENERAL NOTES:**
1. CONTRACTOR TO VERIFY ELEVATIONS AND REPORT TO ENGINEER IF SUBSTANTIALLY DIFFERENT THAN PLANS.
 2. CONTRACTOR SHALL BE RESPONSIBLE FOR ALL SEWER BYPASS ACTIVITIES THAT MAY BE REQUIRED DURING THE CONSTRUCTION OF THE NEW SEWER MAIN & SANITARY SEWER SERVICES.
 3. FOR STREET CUT, TRENCH BACKFILL, TRENCH BEDDING AND PIPE ZONE SEE CITY STANDARD DETAILS 3800-1, 3800-2, 3800-5 & 6200-4.
 4. RESTORE SITE TO AS GOOD OR BETTER CONDITION. THIS INCLUDES REPLACING CURBS, ASPHALT AND RESEEDING.
 5. PROVIDE WORK ZONE TRAFFIC CONTROL IN ACCORDANCE WITH SECTION 00220 AND 00225 AND AS AMENDED BY SPECIAL PROVISIONS.

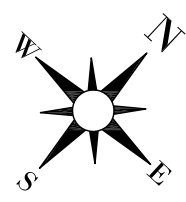

PLOT DATE: December 14, 2020

THIS BAR IS ONE-INCH ON ORIGINAL DRAWING. 	DESIGNED: PG
	DRAWN: PG
	REVIEWED: DG
	APPROVED: DG
	HORIZONTAL DATUM: LOCAL
VERTICAL DATUM: LOCAL	

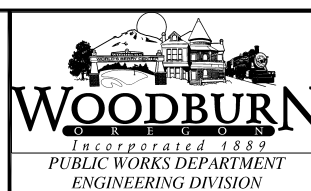

NO.	DATE	DESCRIPTION

SIXTH STREET SANITARY SEWER REPLACEMENT

**900 BLOCK
PLAN AND PROFILE**

PROJECT NO. 2020-013-08
DATE DEC. 2020
SHEET NO. 4

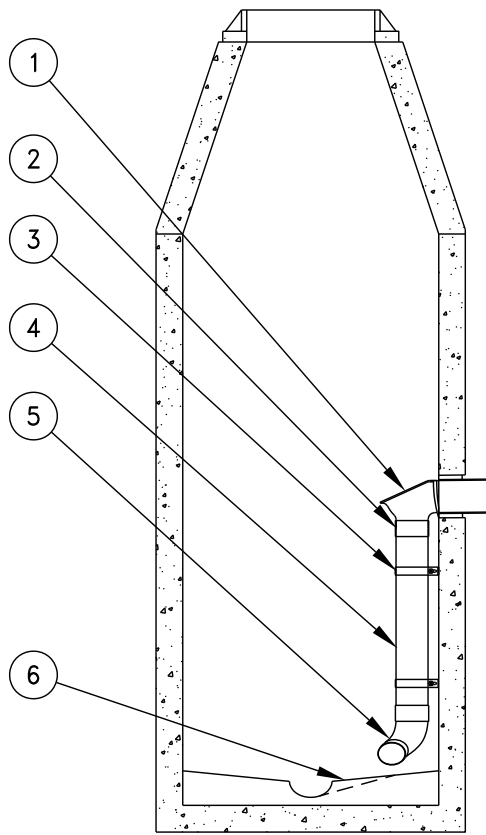

DETAIL NOTES: ○

1. ELINER/DURAN, INC. A6DB DROP BOWL.
2. FLEXBLE PIPE COUPLER.
3. 316/6SS40 PIPE BRACKET (2 REQUIRED).
4. 6" SDR35 3034 PVC DOWN PIPE.
5. 6" X 45° 3034 PVC FITTING.
6. CHANNEL AS REQUIRED FOR SMOOTH FLOW.

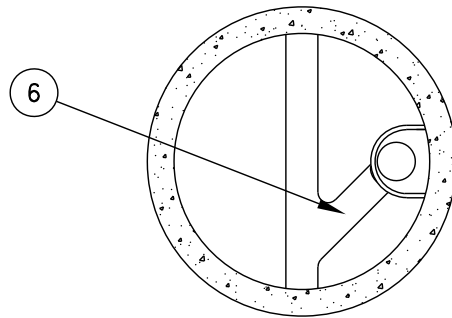

INSIDE DROP DETAIL

PLOT DATE: 12.11.2020

WOODBURN
 O R E G O N
 Incorporated 1889
 PUBLIC WORKS DEPARTMENT
 ENGINEERING DIVISION

PROJECT TITLE:		SIXTH STREET SS REPLACEMENT	
DRAWING NAME:		INSIDE DROP DETAIL	
PROJ. NO:	2020-013-08	DESIGNED:	PJG
DWG. NO:	TB-1	DRAWN BY:	PJG
DATE:	DEC. 2020	REVIEWED:	EL
SCALE:	NTS	APPROVED:	EL

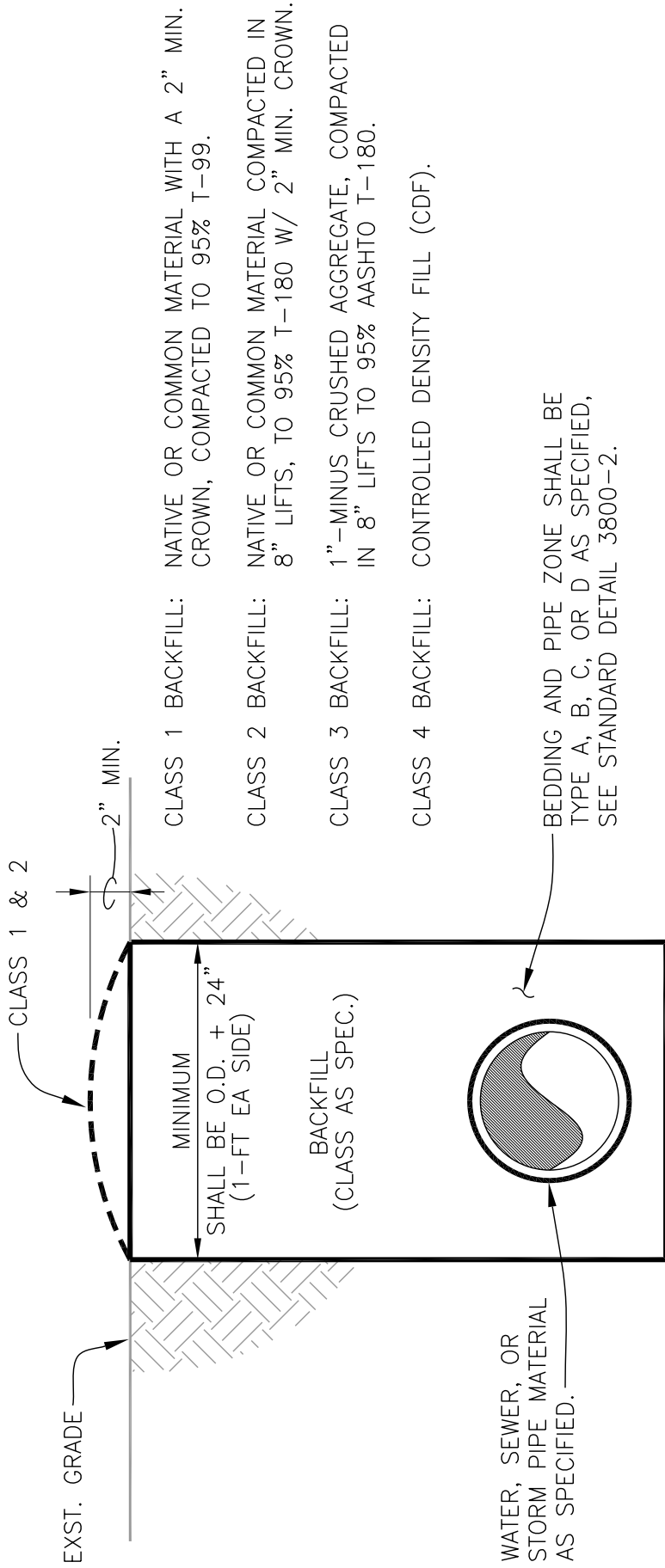

- CLASS 1 BACKFILL: NATIVE OR COMMON MATERIAL WITH A 2" MIN. CROWN, COMPACTED TO 95% T-99.
- CLASS 2 BACKFILL: NATIVE OR COMMON MATERIAL COMPACTED IN 8" LIFTS, TO 95% T-180 W/ 2" MIN. CROWN.
- CLASS 3 BACKFILL: 1"-MINUS CRUSHED AGGREGATE, COMPACTED IN 8" LIFTS TO 95% AASHTO T-180.
- CLASS 4 BACKFILL: CONTROLLED DENSITY FILL (CDF).

NOTES:

1. ENGINEER WILL CONSIDER ADJUSTING USUAL TRENCH WIDTH TO ACCOMMODATE CONDITION ENCOUNTERED.
2. REFERENCE TECHNICAL SPEC. SECTION 3800.
3. FOR HMA TRENCH CAP SURFACE REPLACEMENT SEE DETAIL 3800-5.

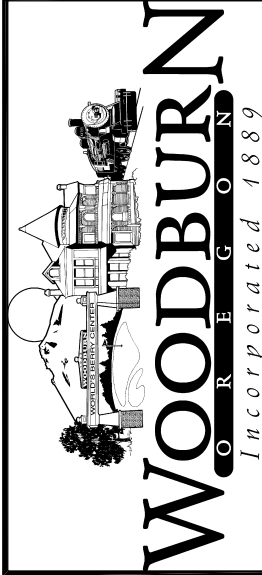

**PUBLIC WORKS DEPARTMENT
ENGINEERING DIVISION**

**PIPE TRENCH
BACKFILL**

REV: DEC. 2007
SCALE: NTS

DET No.

3800-1

BACKFILL AS SPECIFIED, SEE STANDARD DETAIL 3800-1, TYP.

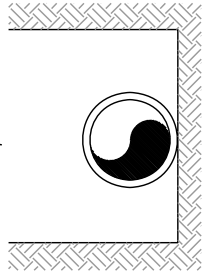

TYPE A

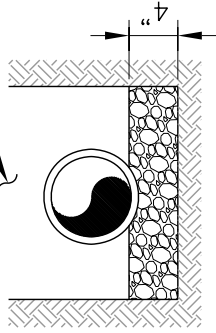

TYPE B

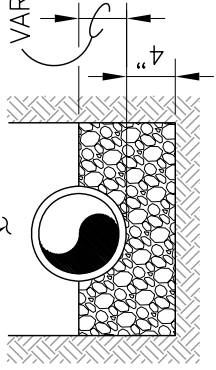

TYPE C

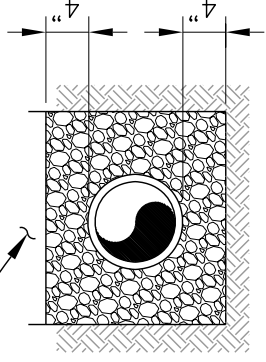

TYPE D

TYPE A - PLACE PIPE BARREL ON UNDISTURBED EARTH.

TYPE B - SUPPORT PIPE ON 4" OF COMPACTED 1"-MINUS CRUSHED AGGREGATE.

TYPE C - PIPE BEDDED WITH 1"-MINUS CRUSHED AGGREGATE FROM 4" BELOW INVERT TO SPRING LINE.

TYPE D - PIPE BEDDED WITH 1"-MINUS CRUSHED AGGREGATE FROM 4" BELOW INVERT TO 4" ABOVE ZENITH.

LEGEND

 UNDISTURBED NATIVE SOIL

 1"-MINUS CRUSHED AGGREGATE,
COMPACTED 95 PCT. OF AASHTO T-99

NOTES:

1. REFERENCE TECHNICAL SPEC. SECTION 3800.



WOODBURN
ENGINEERING
Incorporated 1889
PUBLIC WORKS DEPARTMENT
ENGINEERING DIVISION

**PIPE TRENCH
BEDDING
AND ZONE**

REV: DEC. 2007

SCALE: NTS

DET No.

3800-2

CONSTRUCT COMPACTED
LEVEL 3, 1/2" DENSE
GRADED HMA TRENCH
CAP, TO 92% OF RICE
THEORETICAL MAX DENSITY

SEE NOTE 1

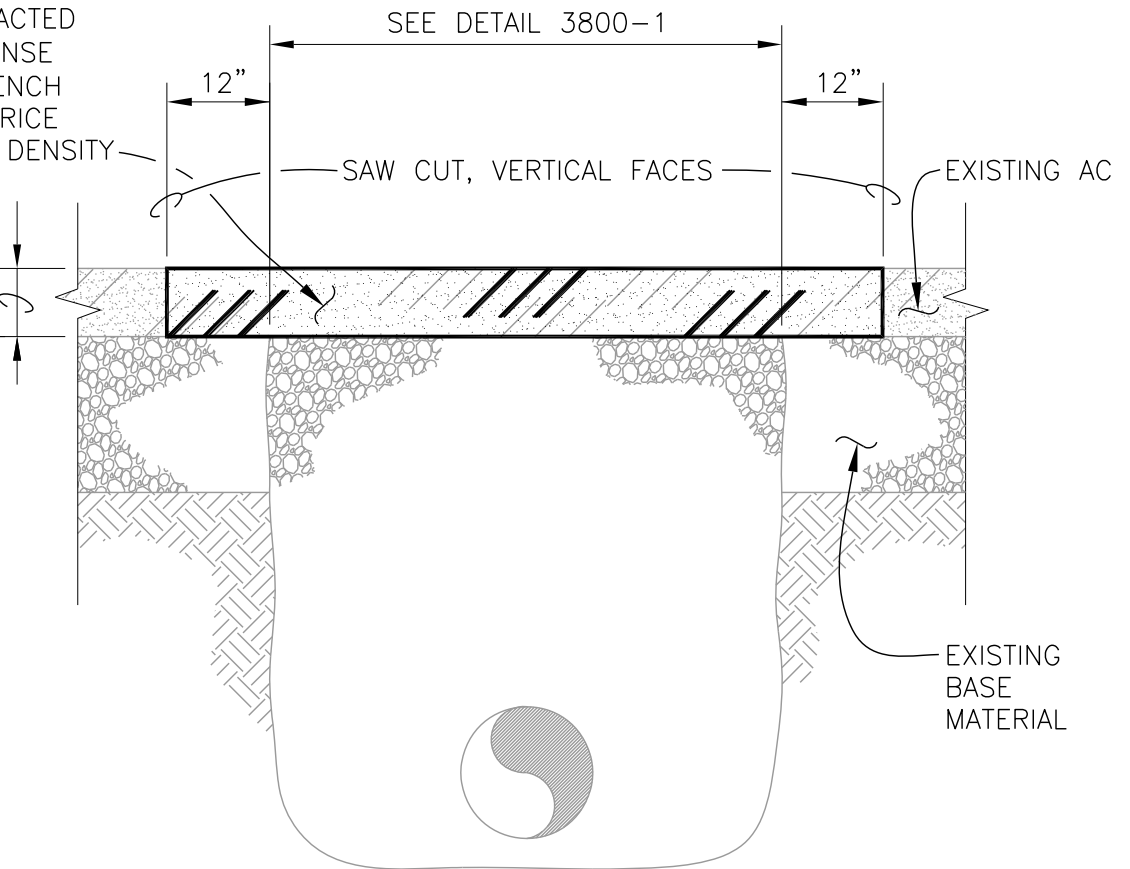

NOTES:

1. REPLACEMENT OF HMA SHALL MATCH EXST. DEPTH UNLESS OTHERWISE SPECIFIED. IN NO CASE SHALL THICKNESS BE LESS THAN THAT SHOWN ON STANDARD DETAIL 4200-1.
2. REFERENCE TECHNICAL SPEC. SECTION 2400, 4200 AND 4220.

WOODBURN
OREGON
Incorporated 1889
PUBLIC WORKS DEPARTMENT
ENGINEERING DIVISION

TRENCH CAP

REV: DEC. 2016

SCALE: NTS

DET No.

3800-5

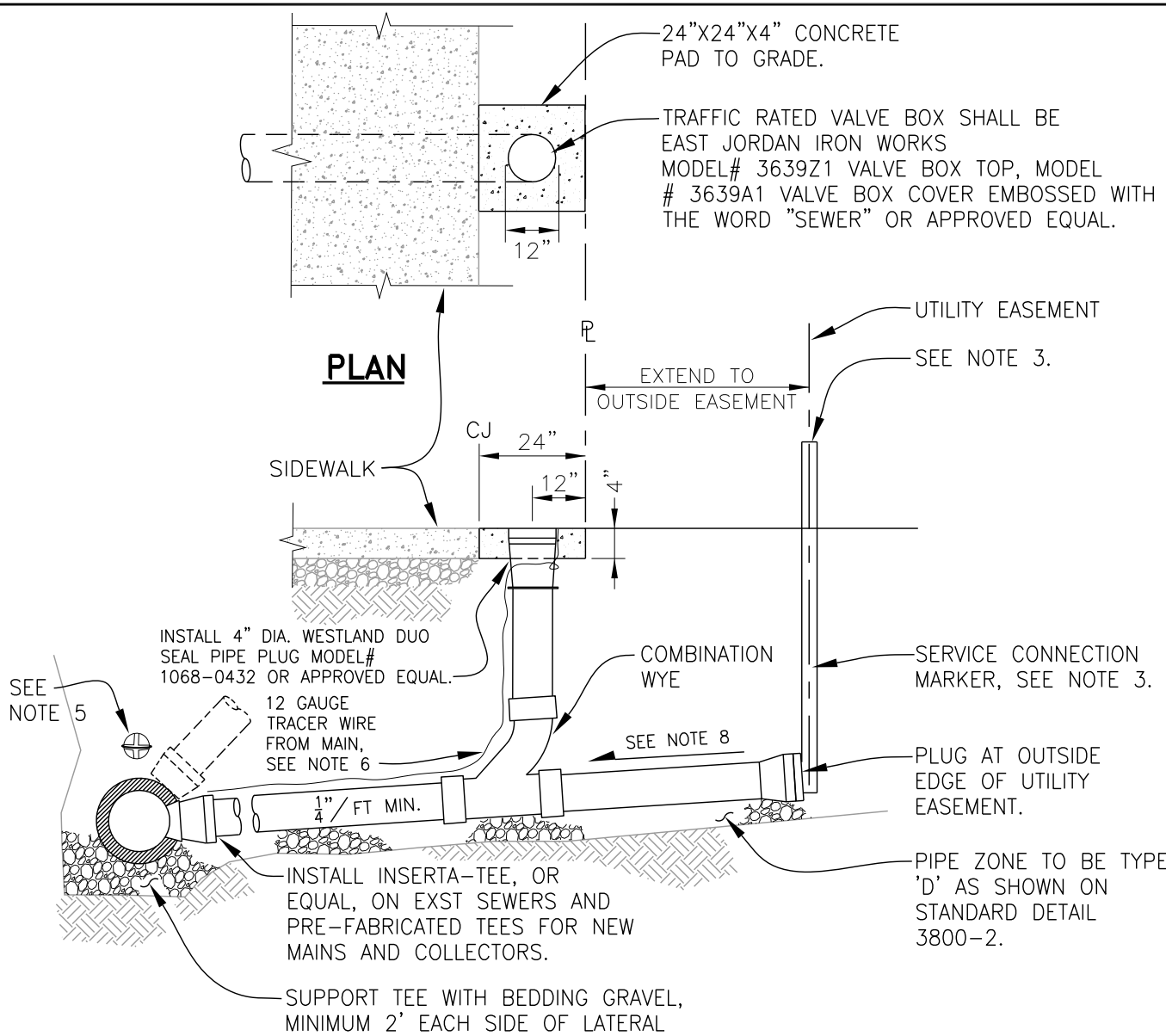

ELEVATION

NOTES:

1. PIPE AND FITTINGS SHALL BE COMPATIBLE. ONLY MANUFACTURED FITTINGS SHALL BE USED.
2. MINIMUM DEPTH AT RIGHT-OF-WAY OR EASEMENT LINE SHALL BE 4 FEET.
3. 2 x 4 FIR. POST TO EXTEND 36" MINIMUM ABOVE FINISH GRADE AND EXPOSED AREA SHALL BE PAINTED GREEN.
4. LAY SANITARY SEWER SERVICE TEE AT MAXIMUM 45°, MINIMUM 20° FROM HORIZONTAL.
5. INSTALL LOCATOR/MARKER BALL AT MAIN LINE CONNECTION 3FT MAX BELOW FINISH GRADE. CONTACT ENGINEERING FOR MORE INFORMATION.
6. INSTALL A CONTINUOUS 12-GAUGE TRACER WIRE FROM MAIN. PLACE TRACER WIRE DIRECTLY OVER PIPE CENTERLINE AND ON TOP OF THE PIPE ZONE MATERIAL.
7. REFERENCE TECHNICAL SPEC. SECTION 6200.
8. CONTACT MARION COUNTY PUBLIC WORKS FOR REQUIREMENTS.

WOODBURN
 O R E G O N
 Incorporated 1889
 PUBLIC WORKS DEPARTMENT
 ENGINEERING DIVISION

SEWER SERVICE CONNECTION

REV: JUNE 2020
SCALE: NTS
DET No. 6200-3

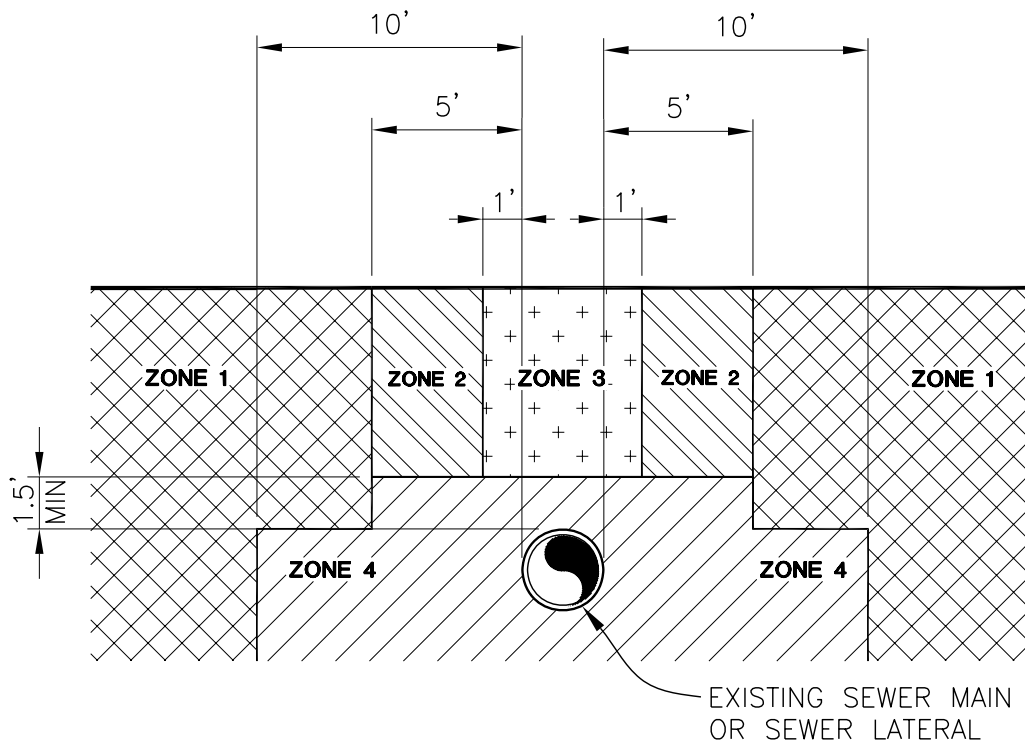

ZONE 1 

WATER LINE CAN BE LAID IN THIS AREA WITH NO SPECIAL REQUIREMENTS OF EITHER CONSTRUCTION OR MATERIALS OTHER THAN THOSE SPECIFIED. CROSSING RESTRICTIONS SHALL APPLY.

ZONE 2 

INSTALLING A WATER MAIN IN THIS ZONE IS NOT ADVISABLE AND MUST BE APPROVED IN EACH CASE. IF ALLOWED, WATER MAIN SHALL BE LOCATED MINIMUM 1.5' ABOVE ZENITH OF SEWER PIPE.

ZONE 3 

WATER MAIN CONSTRUCTION IS NOT PERMITTED.

ZONE 4 

WATER MAIN CONSTRUCTION IS NOT PERMITTED.

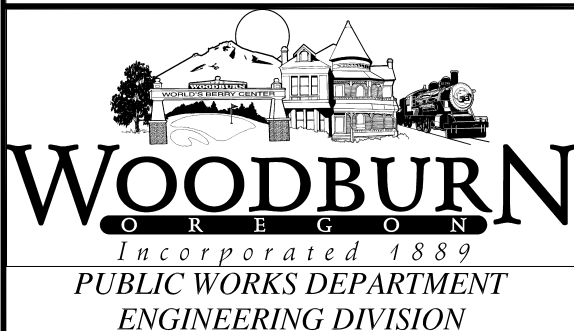

UTILITY ZONES AT SEWER LINE

REV: DEC. 2007

SCALE: NTS

DET No.

6200-4

CONSTRUCT INVERT CHANNELS TO UNIFORM FLOW LINES WITH GRADUAL TRANSITION SECTIONS

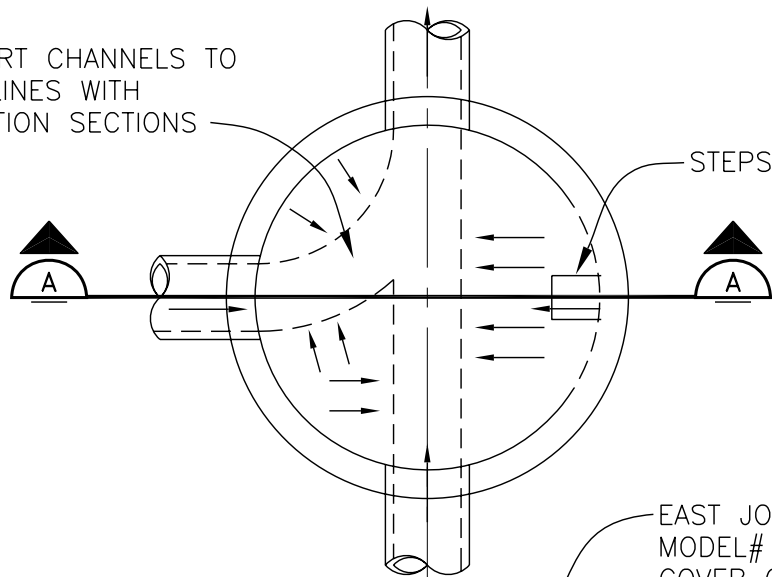

STEPS

EAST JORDAN IRON WORKS
MODEL# 2600 FRAME & 2603
COVER OR APPROVED EQUAL.

SEE NOTE 1

ECCENTRIC MH TOP

FERNCO CMA OR
APPROVED EQUAL.

EXTEND PIPE INTO MH
& GROUT SMOOTH

1" - MINUS
CRUSHED
AGGREGATE

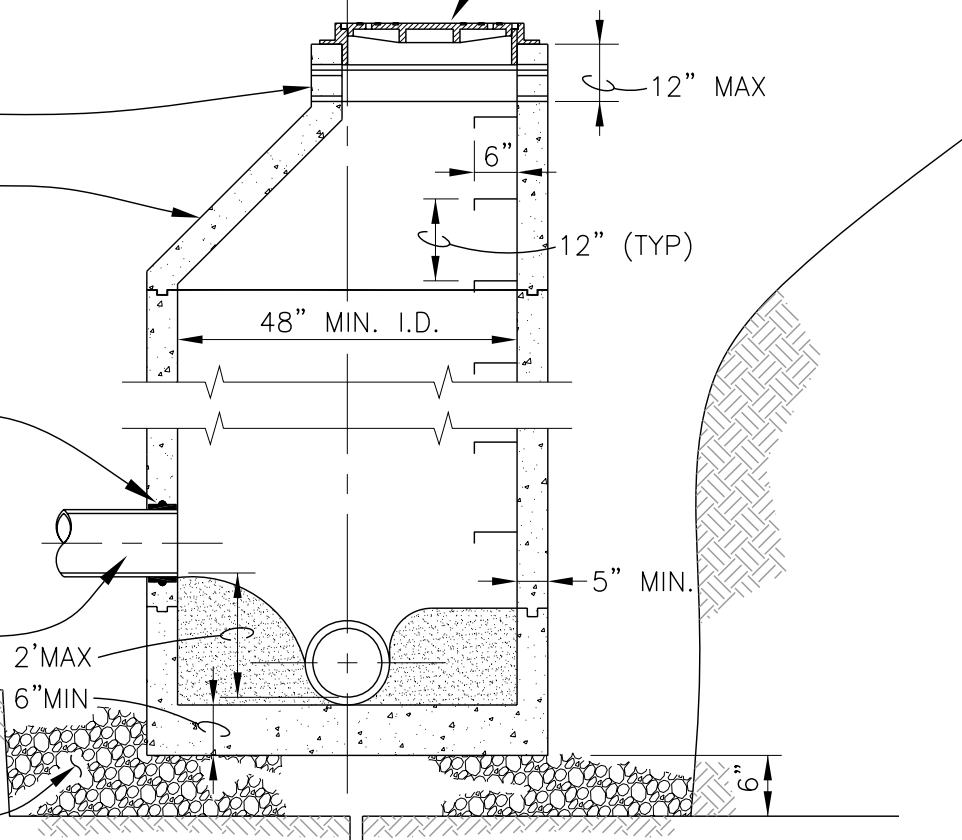

SECTION A

NOTES:

1. MANHOLE JOINTS: CONCRETE EXTENSION RING SHALL BE SEALED WATERTIGHT. REFERENCE TECHNICAL SPEC. SECTION 6510.

WOODBURN
OREGON
Incorporated 1889
PUBLIC WORKS DEPARTMENT
ENGINEERING DIVISION

**SANITARY
SEWER
MANHOLE**

REV: DEC. 2007

SCALE: NTS

DET No.

6510-3

rd345.dgn 20-JUL-2020

RD345

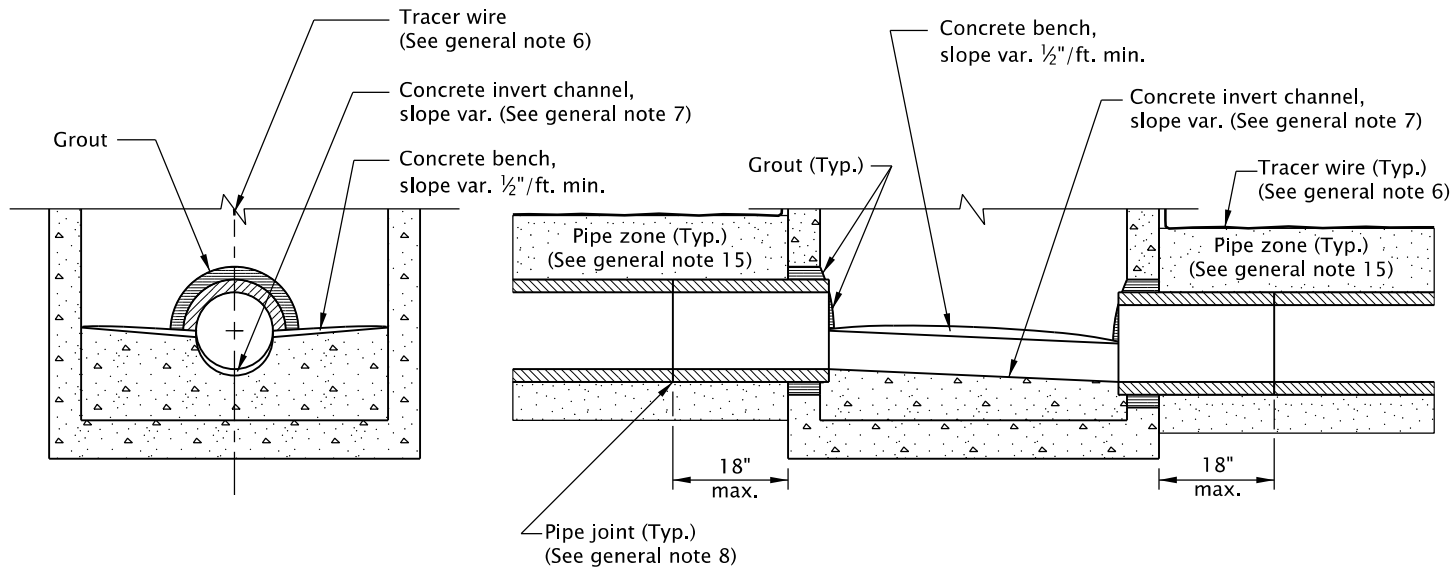

SECTION B-B

SECTION A-A

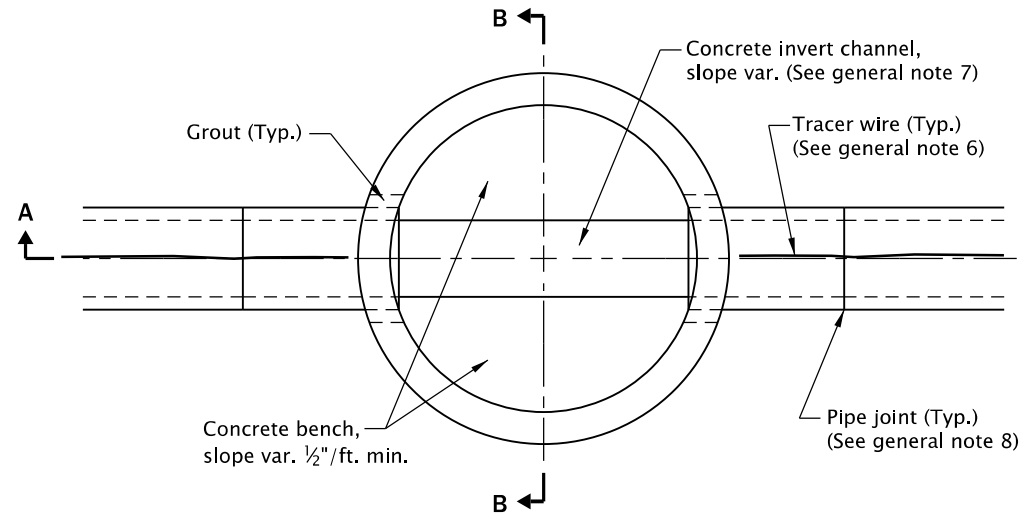

PLAN

CONNECTION OF RIGID PIPE TO MANHOLE

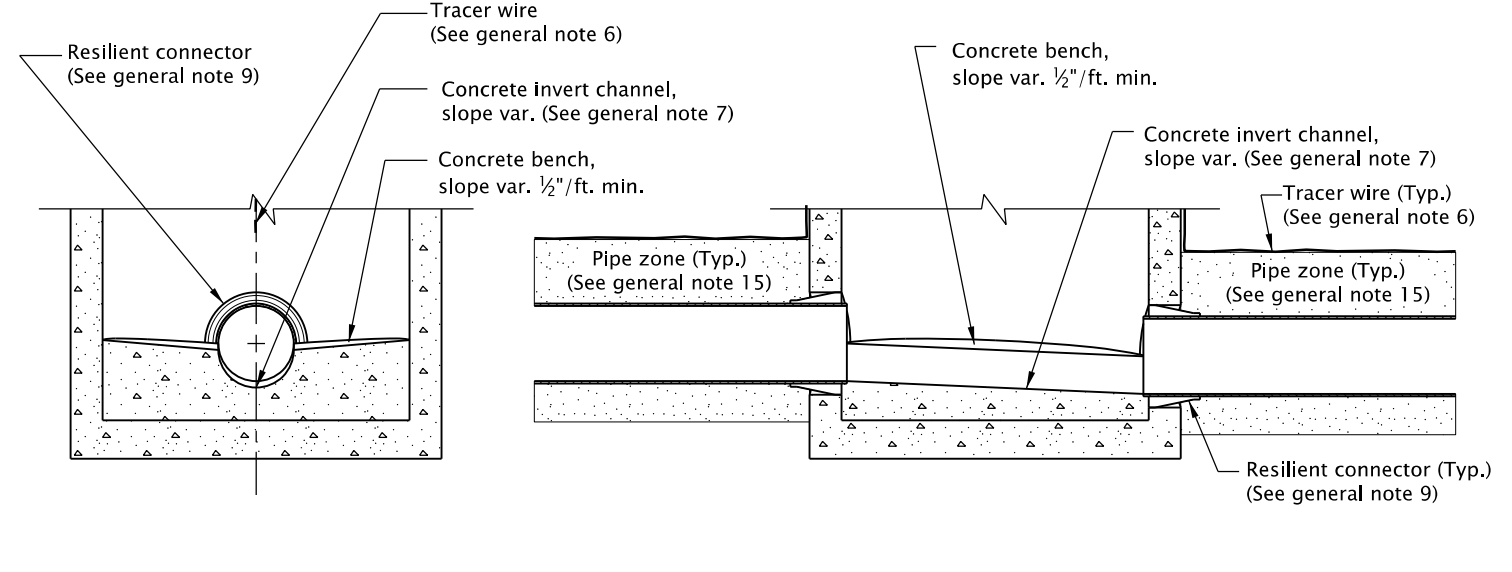

SECTION B-B

SECTION A-A

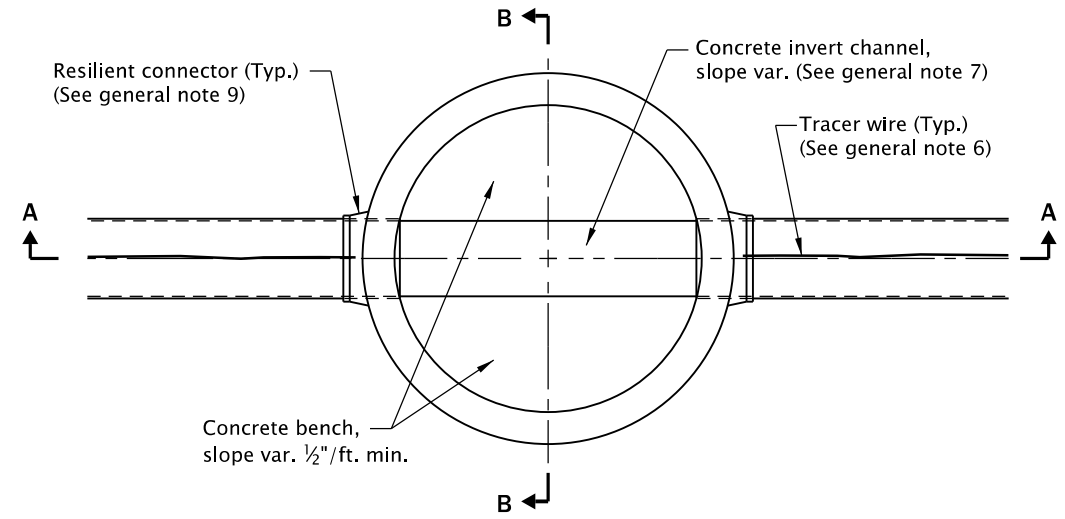

PLAN

CONNECTION OF FLEXIBLE PIPE TO MANHOLE

GENERAL NOTES FOR ALL DETAILS ON THIS SHEET:

1. All precast sections shall conform to requirements of ASTM C478.
2. Manhole base sections may be precast or cast-in-place.
3. All concrete shall be commercial grade concrete.
4. Location, elevation, diameter, slope, and number of pipe(s) varies, see project plans.
5. Max. pipe diameter varies with pipe material.
6. All connecting pipes shall have a tracer wire, or approved alternate. See Std. Dwg. RD336 for tracer wire details.
7. Invert channels shall be constructed to provide smooth slopes and radii to outlet pipe.

8. When rigid pipe is used, the connecting pipe shall have a flexible, gasketted and unrestrained joint within 18" of manhole wall. Joint type varies with manufacturer.
9. When flexible pipe is used, install resilient connectors conforming to requirements of ASTM C923.
10. See Std. Dwgs. RD335, RD336, and RD338 for details not shown.
11. See Std. Dwg. RD336 for manhole steps details.
12. See Std. Dwg. RD342 for shallow manholes.
13. See Std. Dwg. RD344 for manhole base section.
14. See Std. Dwg. RD356 for manhole covers and frames, manhole adjustment rings, etc.
15. Pipe zone varies, see Std. Dwg. RD300.

CALC. BOOK NO. N/A

SDR DATE 14-JUL-2014

NOTE: All material and workmanship shall be in accordance with the current Oregon Standard Specifications

OREGON STANDARD DRAWINGS
PIPE TO MANHOLE CONNECTIONS

2021

DATE	REVISION DESCRIPTION

The selection and use of this Standard Drawing, while designed in accordance with generally accepted engineering principles and practices, is the sole responsibility of the user and should not be used without consulting a Registered Professional Engineer.

