

ADDENDUM

Addendum No.: 1
Project Name: Sixth Street Sanitary Sewer Replacement
Project No. 2020-013-08
Date: January 5, 2021
To: All Bidders

NOTE: This Addendum forms part of the Contract Documents and modifies the drawings and specifications under Bid No. 2021-04 , as noted below. Bidders submitting an offer must sign this form, acknowledging receipt of addendum, and supply it with their proposal. Failure to do so will subject the Bidder to disqualification.

REVISIONS TO DRAWINGS:

Drawing Sheets 3 and 4:

Change Plan Note #4 on sheet 3 and Plan Note #3 on Sheet 4 from Class 1 backfill to Class 3 backfill per Standard Detail 3800-1.

Drawing Standard Detail 3800-5:

Replace Standard Detail 3800-5 with the attached Revised Standard detail 3800-5 showing a minimum 4" HMA thickness.

REVISIONS TO Bid DOCUMENTS:

Appendix A is not missing. Rename Appendix B to Appendix A

I have received, read and incorporated changes, per this addendum, in my proposed bid:

Signature

Date

CONSTRUCT COMPACTED
LEVEL 3, 1/2" DENSE
GRADED HMA TRENCH
CAP, TO 92% OF RICE
THEORETICAL MAX DENSITY

SEE NOTE 1

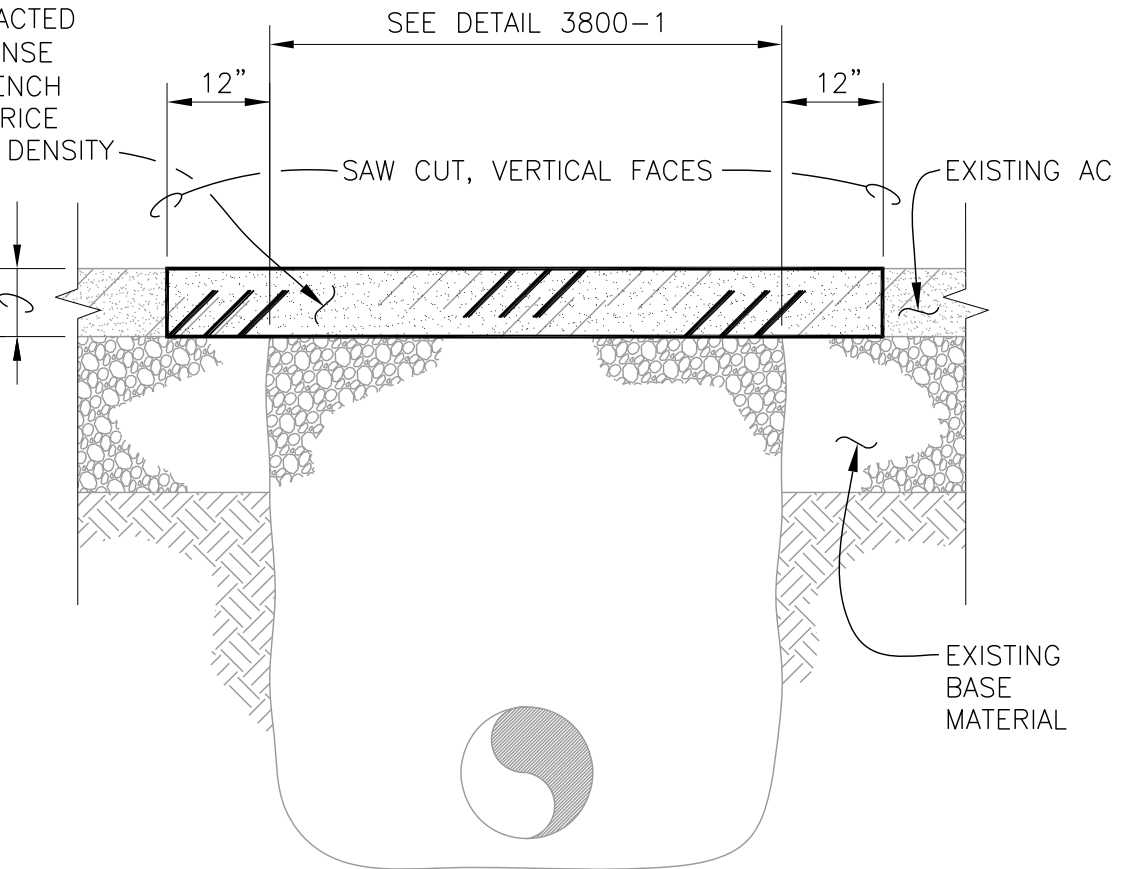

NOTES:

1. REPLACEMENT OF HMA SHALL MATCH EXST. DEPTH (4-INCH MINIMUM), OR OTHERWISE SPECIFIED ON PLANS. IN NO CASE SHALL THICKNESS BE LESS THAN THAT SHOWN ON STANDARD DETAIL 4200-1.
2. REFERENCE TECHNICAL SPEC. SECTION 2400, 4200 AND 4220.



WOODBURN
OREGON
Incorporated 1889
PUBLIC WORKS DEPARTMENT
ENGINEERING DIVISION

TRENCH CAP

REV: DEC. 2016

SCALE: NTS

DET No.

3800-5